



WARRANTY REGISTRATION  
[enviro.com/warranty](http://enviro.com/warranty)

# Westport - Cast

## FREESTANDING GAS FIREPLACE

---

# OWNER'S MANUAL



**Intertek**  
C#4001609

**WARNING:** If the information in this manual is not followed exactly, a fire or explosion may result causing property damage, personal injury or loss of life. Installation and service must be performed by a qualified installer, service agency or the gas supplier.

CERTIFIED TO: ANSI Z21.88 / CSA 2.33 VENTED GAS FIREPLACE HEATERS

CSA 2.17 GAS FIRED APPLIANCES FOR HIGH ALTITUDES

# SAFETY PRECAUTIONS



## **WARNING:**

### **FIRE OR EXPLOSION HAZARD**

**Failure to follow safety warnings exactly could result in serious injury, death, or property damage.**

- Do not store or use gasoline or other flammable vapors and liquids in the vicinity of this or any other appliance.
  
- **WHAT TO DO IF YOU SMELL GAS**
  - Do not try to light any appliance.
  - Do not touch any electrical switch; do not use any phone in your building.
  - Leave the building immediately.
  - Immediately call your gas supplier from a neighbor's phone. Follow the gas supplier's instructions.
  - If you cannot reach your gas supplier, call the fire department.
  
- Installation and service must be performed by a qualified installer, service agency or the gas supplier.

### **INSTALLER:**

Leave this manual with the appliance.

### **CONSUMER:**

Retain this manual for future reference.

This appliance may be installed in an after-market permanently located, manufactured (mobile) home, where not prohibited by local codes.

This appliance is only for use with the type of gas indicated on the rating plate. This appliance is not convertible for use with other gases, unless a certified kit is used.

Massachusetts installations (Warning): This product must be installed by a licensed plumber or gas fitter when installed within the Commonwealth of Massachusetts. Other Massachusetts code requirements: Flexible connector must not be longer than 36in., a shut off valve must be installed; only direct vent sealed combustion products are approved for bedrooms/bathrooms. A carbon monoxide detector is required in all rooms containing gas fired direct vent appliances. The fireplace damper must be removed or welded in the open position prior to installation of a fireplace insert.

# SAFETY PRECAUTIONS

FOR SAFE INSTALLATION AND OPERATION OF YOUR "ENVIRO" HEATER, PLEASE CAREFULLY READ THE FOLLOWING INFORMATION:

- All ENVIRO gas-fired appliances must be installed in accordance with their instructions. Carefully read all the instructions in this manual first. Consult the building authority having jurisdiction to determine the need for a permit prior to commencing the installation.
- **NOTE:** Failure to follow these instructions could cause a malfunction of the fireplace, which could result in death, serious bodily injury, and/or property damage.
- Failure to follow these instructions may also void your fire insurance and/or warranty.

## GENERAL

• Installation and repair should be done by a qualified service person. The appliance should be inspected before the first use and, at least, annually by a qualified service person. More frequent cleaning may be required due to excessive lint from carpeting, bedding material, etc. It is imperative the control compartments, burners and circulating air passageways of the appliance be kept clean.

• Due to high temperatures, the appliance should be located out of high traffic areas and away from furniture and draperies.

**Children and adults should be alerted to the hazards of high surface temperatures and should stay away to avoid burn or clothing ignition.**

• Young children should be carefully supervised when in the same room as the appliance. Toddlers, young children and others may be susceptible to accidental contact burns. A physical barrier is required if there are at risk individuals in the house. To restrict access to a fireplace or stove install an adjustable safety gate to keep toddlers, young children and other at risk individuals out of the room and away from hot surfaces. Any safety screen, guard, or barrier removed for servicing an appliance must be replaced prior to operating the appliance.

• Clothing or other flammable materials should not be placed on or near the appliance.

• A barrier designed to reduce the risk of burns from the hot viewing glass is provided with this appliance and shall be installed for the protection of children and other at-risk individuals. If the barrier becomes damaged, the barrier shall be replaced with the manufacturer's barrier for this appliance

## FOR YOUR SAFETY

• Installation and service must be performed by a qualified installer, service agency or gas supplier.

• This installation must conform to local codes or, in the absence of local codes, with the National Fuel Gas Code, ANSI Z223.1/NFPA 54, or the Natural Gas and Propane Installation Code, CSA B149.1.

• To prevent injury, do not allow anyone who is unfamiliar with the stove to operate it.

**• To prevent injury, if the pilot or pilot and burners have gone out on their own, open the glass door and wait 5 minutes to air out before attempting to re-light the stove.**

• Always keep the area around these appliances clear of combustible material, gasoline and other flammable liquids and vapours.

• These appliances should not be used as a drying rack for clothing or for hanging Christmas stockings/decorations.

• Due to the paint curing on the stove, a faint odor and slight smoking will likely be noticed when the stove is first used. Open a window until the smoking stops.

Always connect this gas stove to a vent system and vent to the outside of the building envelope. Never vent to another room or inside the building. Make sure the specified vent pipe is used, properly sized and of adequate height to provide sufficient draft. Inspect the venting system annually for blockage and signs of deterioration.

**WARNING:** Failure to position the parts in accordance with the diagrams in this booklet, or failure to use only parts specifically approved with this appliance, may result in property damage or personal injury.

**WARNING:** Do not operate with the glass front removed, cracked or broken. Replacement of the glass should be done by a licensed or qualified service person.

• Never use solid fuels such as wood, paper, cardboard, coal, or any flammable liquids, etc., in this appliance.

• Do not use this appliance if any part has been under water. Immediately call a qualified service technician to inspect the appliance and to replace any part of the control system or any gas control which has been under water.

• Do not abuse the glass by striking it or slamming the door shut.

• If the Westport unit is pulled out of its installation, and the vent-air intake system is disconnected for any reason, ensure that the vent-air intake pipes are reconnected and resealed in accordance to the instructions noted in the INITIAL INSTALLATION section of the manual.



## DANGER



**HOT GLASS WILL  
CAUSE BURNS**

**DO NOT TOUCH GLASS  
UNTIL COOLED.**

**NEVER ALLOW CHILDREN  
TO TOUCH GLASS.**

A barrier designed to reduce the risk of burns from the hot viewing glass is provided with this appliance and must be installed for the protection of children and other at-risk individuals.

# TABLE OF CONTENTS

---

<b>Safety Precautions</b> .....	<b>2</b>
<b>Table of Contents</b> .....	<b>4</b>
<b>Codes And Approvals</b> .....	<b>6</b>
<b>Specifications</b> .....	<b>7</b>
Dimensions: .....	7
Rating Label Location:.....	7
<b>Operating Instructions</b> .....	<b>8</b>
Pilot Lighting Instructions: .....	8
Pilot Light:.....	9
Air Shutter: .....	9
Remote controls (Optional):.....	10
Blower Speed (Optional): .....	10
Normal Sounds During Operation:.....	10
<b>Maintenance And Service</b> .....	<b>11</b>
Routine Maintenance: .....	11
Cleaning The Glass: .....	11
Cleaning The Firebox: .....	11
Change Battery in Ignition Module: .....	11
Burner Removal:.....	12
Replacing the Glass:.....	12
Glass Door Removal:.....	12
Fuel Conversion: .....	13
<b>Initial Installation</b> .....	<b>16</b>
Preparation For Installation: .....	16
Clearances to Combustibles: .....	16
Planning Your Installation:.....	16
Vent Termination Restrictions:.....	18
Vent Configurations and Restrictor Settings:.....	20
Horizontal Installation: .....	21
Vertical Installation: .....	23
Cathedral Ceiling Installation: .....	25
Corner Installations:.....	26
Converting Top Vented into Rear Vented:.....	27
Installation of Rear Vented Appliance: .....	28
Installation of Top Vented; Horizontal Termination:.....	29
Installation of Top Vented; Vertical Termination:.....	29
Freestanding Drafthood Adaptor - 50-841:.....	30
Gas Line Connection and Testing: .....	33
Electrical Requirements For Gas Valve and Optional Blower:.....	34

# TABLE OF CONTENTS

---

<b>Secondary Installation</b> .....	<b>35</b>
Installation of Optional Blower: .....	35
Installation of Log Set and Embers:.....	35
Installation of Panel Set: .....	38
Installation of Safety Screen: .....	39
<b>Trouble Shooting</b> .....	<b>40</b>
<b>Parts List - Cast</b> .....	<b>41</b>
<b>Parts List - Components</b> .....	<b>42</b>
<b>Parts Diagram - Components</b> .....	<b>44</b>
<b>Installation Data Sheet</b> .....	<b>46</b>

# CODES AND APPROVALS

**DIRECT VENT ONLY:** This type is identified by the suffix DV. This appliance draws all of its air for combustion from outside the dwelling, through a specially designed vent pipe system.

**TOP VENT DV** Certified for installation from 0-4500 ft (0-1372 m)

**REAR VENT DV** Certified for installation from 0-4500 ft (0-1372 m) with 36" (915 mm) snorkel (refer to 'Converting Top Vented into Rear Vented').

**In the USA:** The appliance may be installed at higher altitudes. Please refer to your American Gas Association guidelines which state: the sea level rated input of Gas Designed Appliances installed at elevations above 2000 (610 m) feet is to be reduced 4% for each 1000 feet (305 m) above sea level. Refer also to local authorities or codes which have jurisdiction in your area regarding the de-rate guidelines.

**In Canada:** When the appliance is installed at elevations above 4500 feet (1372 m), the certified high altitude rating shall be reduced at the rate of 4% for each additional 1000 feet (305 m).

- This appliance has been tested by INTERTEK and found to comply with the established VENTED GAS FIREPLACE HEATER standards in CANADA and the USA as follows:

## VENTED GAS FIREPLACE HEATER (Westport DV; NG/LPG)

TESTED TO: ANSI Z21.88/CSA 2.33 VENTED GAS FIREPLACE HEATERS

CSA 2.17 GAS FIRED APPLIANCES FOR HIGH ALTITUDES

CSA P.4.1 TESTING METHOD FOR MEASURING ANNUAL FIREPLACE EFFICIENCY

### This ENVIRO WESTPORT Fireplace:

- Has been certified for use with either natural or propane gases. (See rating label.)
- Is not for use with solid fuels.
- Is approved for bedroom or bed sitting room. (**IN CANADA:** must be installed with a listed wall thermostat. **IN USA:** see current ANSI Z223.1 for installation instructions.)
- Must be installed in accordance with local codes. If none exist, use current installation code CAN/CGA B149 in Canada or ANSI Z223.1/NFPA 54 in the USA.
- Must be properly connected to an approved venting system and not connected to a chimney flue serving a separate solid-fuel burning appliance.

**IMPORTANT NOTICE (Regarding first fire up):** When the unit is turned on for the first time, it should be turned onto high without the fan on for the first 4 hours. This will cure the paint, logs, gasket material and other products used in the manufacturing process. It is advisable to open a window or door, as the unit will start to smoke and can irritate some people. After the unit has gone through the first burn, turn the unit off including the pilot, let the unit get cold then remove the glass door and clean it with a good gas fireplace glass cleaner, available at your local ENVIRO dealer.

NATIONAL  
FIREPLACE  
INSTITUTE



CERTIFIED

[www.nficertified.org](http://www.nficertified.org)

We recommend that our gas hearth products be installed and serviced by professionals who are certified in the U.S. by the National Fireplace Institute® (NFI) as NFI Gas Specialists.

# SPECIFICATIONS

## WARNING:

Operation of this heater when not connected to a properly installed and maintained venting system can result in carbon monoxide (CO) poisoning and possible death.

## DIMENSIONS:

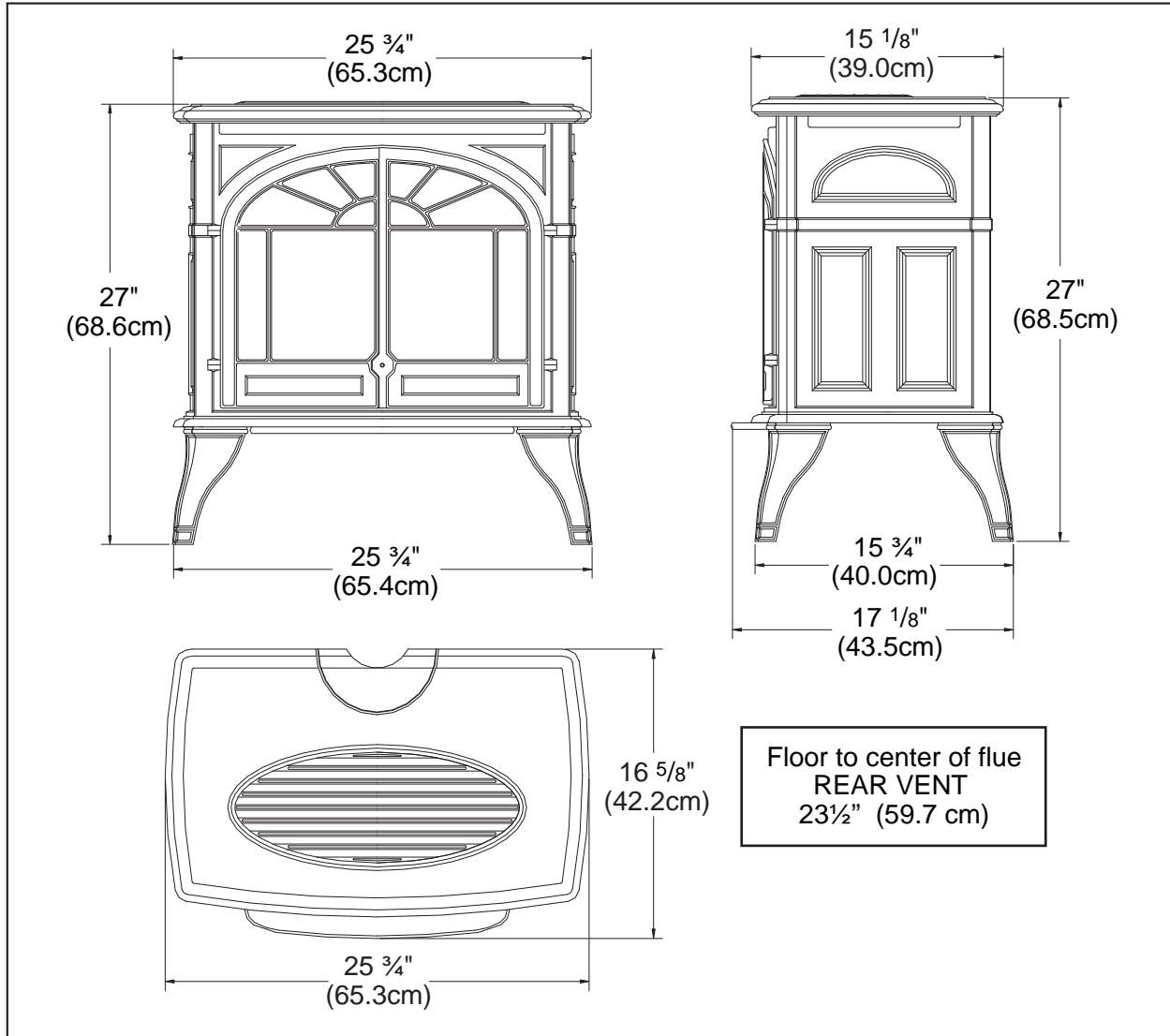

Figure 1: Westport Exterior Dimensions.

## RATING LABEL LOCATION:

The Rating Label is located on a plate hang on the back left of the unit.

# OPERATING INSTRUCTIONS

## For Your Safety, Read Safety Precautions And Lighting Instructions Before Operating

**WARNING: IF YOU DO NOT FOLLOW THESE INSTRUCTIONS EXACTLY A FIRE OR EXPLOSION MAY RESULT, CAUSING PROPERTY DAMAGE, PERSONAL INJURY OF LOSS OF LIFE.**





### PILOT LIGHTING INSTRUCTIONS:

#### FOR YOUR SAFETY READ BEFORE LIGHTING

**WARNING:** If you do not follow these instructions exactly, a fire or explosion may result causing property damage, personal injury or loss of life

- A. This appliance has a pilot which must be lighted by hand. When lighting the pilot, follow these instructions exactly.
- B. BEFORE LIGHTING smell all around the appliance area for gas. Be sure to smell next to the floor because some gas is heavier than air and will settle on the floor.
- WHAT TO DO IF YOU SMELL GAS:  
Do not try to light any appliance. Do not touch any electrical switch; do not use any phone in your building. Immediately call your gas supplier from a neighbor's phone. Follow the gas supplier's instructions.
- C. Use only your hand to push in or turn the gas control knob. Never use tools. If the knob will not push in or turn by hand, don't try to repair it. Call a qualified service technician. Force or attempted repair may result in a fire or explosion.
- D. Do not use this appliance if any part has been under water. Immediately call a qualified service technician to inspect the appliance and to replace any part of the control system and any gas control which has been under water.

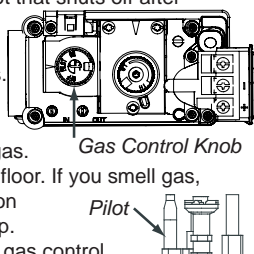
#### LIGHTING INSTRUCTIONS

- STOP! Read the safety information above on this label.
  - Set the thermostat to the lowest setting.
  - This appliance is equipped with an on-demand pilot that shuts off after 7 consecutive days of main burner inactivity.
  - Turn off all electric power to this appliance.
  - Open the front control panel for valve knob access.
  - Turn off the gas control knob clockwise  to the "OFF" position.
  - Open door. Wait five (5) minutes to clear out any gas. Close door. Then smell for gas, including near the floor. If you smell gas, STOP! Follow "B" in the safety information above on this label. If you don't smell gas, go to the next step.
  - Find pilot - located close to the burner(s). Turn the gas control knob counter-clockwise  to "PILOT". Push the gas control in fully and hold, keep knob depressed for about 60 seconds after the pilot is lit or until an audible "BEEP" is heard. Release knob. If pilot goes out, repeat steps 4 through 5. **WARNING:** This gas valve has a lockout device, which will not allow the pilot burner to be relit until the thermocouple has cooled.  
-If the knob does not pop up when released, stop and immediately call your service technician or gas supplier.  
-If the pilot will not stay lit after several tries, turn the gas control knob clockwise  to "OFF" and call your service technician or gas supplier.
- 
- Turn the gas control knob counter clockwise  to the "ON" position. Flip the burner switch to "ON" then turn the "HI/LOW" knob to the desired setting.
  - Close the front control panel.
  - Turn on all electric power to the appliance.
  - Set thermostat to desired setting.

#### TO TURN OFF GAS TO APPLIANCE

- Set the thermostat to the lowest setting.
- Turn off all electric power to the appliance if service is to be performed.
- Open the front control panel and flip burner switch to "OFF"
- Turn the gas control knob clockwise  to the "OFF" position.
- Close the front control panel.

C-16294

Figure 2: Lighting Instruction Label



# OPERATING INSTRUCTIONS

## PILOT LIGHT:

1. Turn off the gas to the fireplace. **If not recently done, remove the glass and let the unit air out for at least five (5) minutes to clear out any gas.** Turn on gas to the heater. Leak test all joints with soapy water. **NEVER USE OPEN FLAME FOR LEAK TESTING.**
2. Start the pilot by pressing the gas control knob and turning it to PILOT. While holding the gas control knob in, press the piezo ignitor several times until the pilot light starts. Hold the gas control knob in for 30 seconds. Check that the pilot has fully engulfed the thermocouple assembly (see Figure 3).
3. Start the main burner by turning the gas control knob to ON and then turn the rocker switch to ON. Check that all burner ports have flame.
4. Leak test all gas joints again.

**\*NOTE: This appliance is equipped with an on-demand pilot that, if left dormant, will shut down after seven (7) consecutive days.**

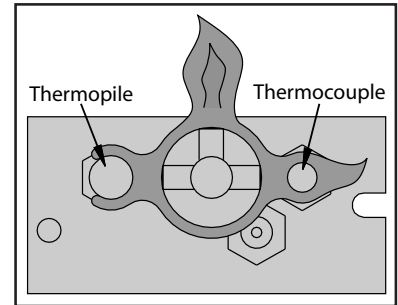

Figure 3: Pilot Flame

## AIR SHUTTER:

The air shutter is controlled with the primary air adjustment rod located behind the gas valve shown in Figure 4.

The air shutter allows the amount of air coming into the fireplace to be adjusted in order to accommodate different climates and venting arrangements. Start the pilot and then the burner. Make sure the pilot flame is burning normally and none of the burner ports are plugged. Let the fireplace burn for roughly fifteen (15) minutes and then examine the flames, compare the flames to Figure 59.

The ideal flame will be blue at the base and light orange above. The flames should be of medium height. If the flames look like this, no venturi adjustment is needed. If the flames are fairly short and mostly blue, the fireplace is getting too much air. Therefore, the air shutter should be closed slightly until the correct flames are achieved. Flames that are very orange, with tall, dark, stringy tips, are not getting enough air. Open the venturi until the flames clean up. If the venturi is opened, or closed all the way, and the correct flames cannot be attained, turn off the gas and contact the dealer.

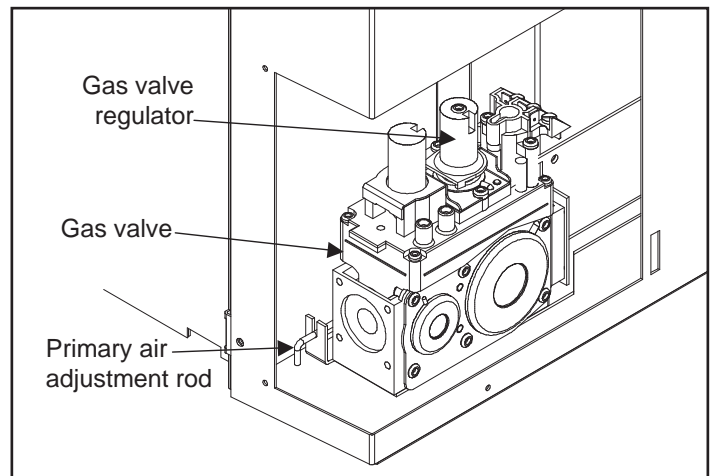

Figure 4: Gas Valve In Place on Unit.

Table 1: Venturi Information

	Natural Gas	Propane
Venturi Setting	1/16" min.	3/16" min.

**Warning:** Incorrect venturi adjustment may lead to improper combustion, which is a safety hazard. Contact the dealer if there is any concern about the venturi adjustment.

# OPERATING INSTRUCTIONS

---

## For Your Safety, Read Safety Precautions And Lighting Instructions Before Operating

### REMOTE CONTROLS (OPTIONAL):

---

This fireplace can use an optional remote control or an optional cordless wall thermostat. If either of these are to be used to control the fireplace for the majority of the time, leave the ON/OFF switch (on the control panel) in the remote/thermostat position. Consult the instructions included with the remote/wall thermostat for operation guidelines.

### BLOWER SPEED (OPTIONAL):

---

The blower will come on only when the fireplace is up to temperature (approximately 20 minutes). The speed of the fan can be changed by turning the fan control knob. To turn the blower off, turn the knob COUNTER CLOCKWISE until it "clicks" off.

It is advisable not to operate the blower below  $\frac{1}{3}$  speed as it puts a strain on the windings of the blower and running the blower at lower speeds could also cause premature fan failure.

### NORMAL SOUNDS DURING OPERATION:

---

Table 2: Normal Sounds

Component	Sound & Reason
Westport	Creaking when heating up or cooling down.
Burner	Light pop or poof when turned off; this is more common with LP units.
Temperature Sensor	Clinking when it senses to turn the blower on or off.
Pilot Flame	Quiet whisper while the pilot flame in on.
Blower / Fan	Air movement that increase and decreases with the speed of the blower. The blower is pushing the heat from the fireplace into the room.
Gas Control Valve	Dull click when turning on or off, this is the valve opening and closing.

# MAINTENANCE AND SERVICE

---

## **ROUTINE MAINTENANCE:**

---

At least once a year, run through the following procedures to ensure the system is clean and working properly. Check the burner to see if all the ports are clear and clean. Check the pilot to make sure it is not blocked by anything. The pilot flame should be blue with little or no yellow on the tips.

**Warning:** Clearances must be sufficient to allow access for maintenance and service

**Warning:** Failure to position the parts in accordance with this manual, or failure to use only parts specifically approved with this appliance may result in property damage or personal injury.

The venting system must be periodically examined; it is recommended the examination is done by a qualified agency.

## **CLEANING THE GLASS:**

---

**When the fireplace has cooled**, remove the face of the fireplace along with the glass. See MAINTENANCE AND SERVICE - GLASS DOOR REMOVAL. Check the gasket material on the back of the glass, making sure that it is attached and intact.

During a cold start up, condensation will sometimes form on the glass. This is a normal condition with all fireplaces. However, this condensation can allow dust and lint to cling to the glass surface. Initial paint curing of the appliance can leave a slight film behind the glass, a temporary problem. The glass will need cleaning about two weeks after installation. **Use a mild glass cleaner and a soft cloth; abrasive cleaners will damage the glass and plated surfaces.** Depending on the amount of use, the glass should require cleaning no more than two or three times a season. **Do not clean the glass when it is hot.**

## **CLEANING THE FIREBOX:**

---

Remove the logs carefully, as they are very fragile. Gently remove all the embers and rock wool and place on a paper towel. Vacuum the bottom of the firebox thoroughly. Carefully clean any dust off the logs and remove any lint from the burner and pilot. At this time, inspect the burner pan for cracking or severe warping. If a problem is suspected, contact the dealer. Check the logs for deterioration or large amounts of soot; a small amount on the bottom side of the logs is normal. Replace the logs and embers as in the LOG SET AND EMBER INSTALLATION section. If new/more embers and rock wool are required, contact your nearest ENVIRO dealer.

## **CHANGE BATTERY IN IGNITION MODULE:**

---

If the unit does not spark when lighting, the battery in the electronic ignition could need replacing.

Located on the left hand rear corner of the unit is a small rectangular hole. Located here is the electronic ignition module (see Figure 5). Remove the battery cover, located on the left side of the module, and replace the AA battery.

Reinstall the battery cover and check for spark by depressing the pilot knob located on the control panel.

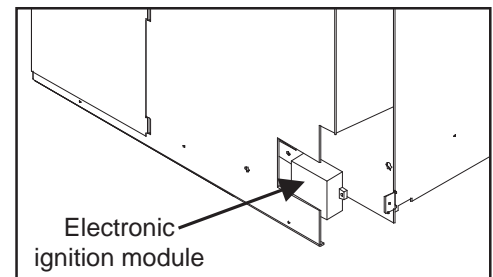

**Figure 5: Electronic Ignition Module Location.**

# MAINTENANCE AND SERVICE

## REPLACING THE GLASS:

The glass in the fireplace is a high temperature ceramic. If the glass is damaged in any way, a factory replacement is required (see PARTS LIST - COMPONENTS). Wear gloves when handling damaged glass door assembly to prevent personal injury. When the glass door assembly is being transported, it must be wrapped in newsprint and tape and/or a strong plastic bag. Do not operate with the glass front removed, cracked or broken. Removal and replacement of the glass from the door **must** be done by a licensed or qualified service person. **The glass must be purchased from an ENVIRO dealer. No substitute materials are allowed.**

### To Replace:

- Open door, and remove the glass carefully.
- Install the new piece of glass with the large bulb in the gasket tape against the unit. Place the joint in the tape in a bottom corner. Close door.

## GLASS DOOR REMOVAL:

Turn unit off and wait until the appliance has cooled down. Remove the cast iron top from the unit by lifting straight up. Lift the two door handles located on either side of the door and lift the glass door assembly straight up and out (see Figure 6 and Figure 7). Carefully open the two doors and remove if necessary.

Ensure the door is properly fastened after cleaning before attempting to re-light the appliance.



Figure 6: Handles for Removing Door.

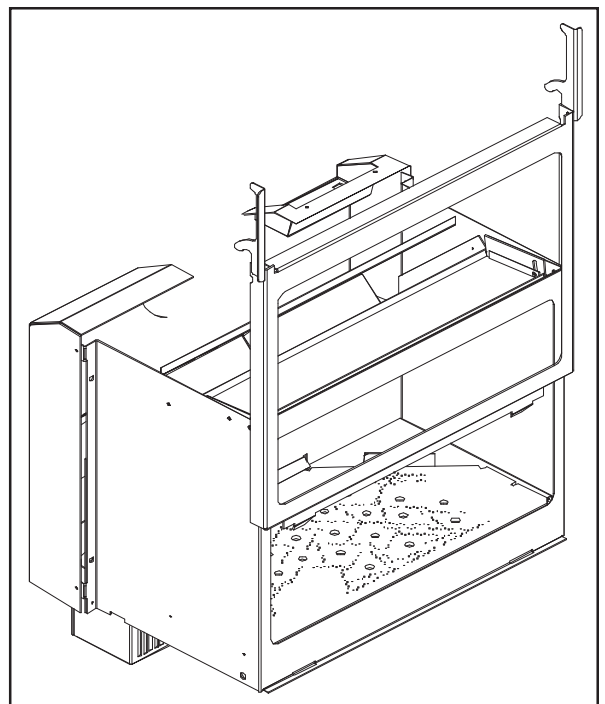

Figure 7: Removing of Door.

## BURNER REMOVAL:

1. Remove the glass as shown in the MAINTENANCE AND SERVICE - GLASS DOOR REMOVAL.
2. Carefully remove the log set and ember material.
3. Remove the two (2) screws (located on the outside edges of the burner) that hold the burner to the chassis inside the fire box, see Figure 8. Remove the burner tray from the firebox.

# MAINTENANCE AND SERVICE

## FUEL CONVERSION:

### TO BE INSTALLED BY A QUALIFIED SERVICE AGENCY ONLY

Please read and understand these instructions before installing.

**Warning:** This conversion kit shall be installed by a qualified service agency in accordance with the manufacturer's instructions and all applicable codes and requirements of the authority having jurisdiction. If the information in these instructions is not followed exactly, a fire, explosion or production of carbon monoxide may result causing property damage, personal injury or loss of life. The qualified service agency is responsible for the proper installation of this kit. The installation is not proper or complete until the operation of the converted appliance is checked as specified in the manufacturer's instructions supplied with the kit.

#### Kit Parts List:

- 1 - Orifice (NG - #39 DMS or LP - #53 DMS)
- 1 - Pilot Injector (NG 0.62 mm; LP 0.35 mm)
- 1 - Installation instruction sheet
- 1 - Conversion label

Carefully inspect all parts supplied with this conversion kit. If any parts have been damaged or are missing, contact your dealer, distributor or courier company to have them replaced before starting this installation.

#### Conversion Kit Installation:

1. Turn control knob on the gas valve to the "OFF" position and shut the gas supply off at the shut-off valve upstream of the unit. **CAUTION:** The gas supply must be shut off prior to disconnecting the electrical power and before proceeding with the conversion. Allow the valve and unit to cool down to room temperature.
2. Remove the glass as shown in the MAINTENANCE AND SERVICE - GLASS DOOR REMOVAL.
3. Carefully remove the log set and ember material if they are installed.
4. Remove the burner as shown in the MAINTENANCE AND SERVICE - BURNER REMOVAL.
5. Convert the burner orifice(s):
  - a) Remove the main burner orifice with a 1/2 inch deep socket.
  - b) Put a bead of pipe-thread sealant or approved Teflon tape on the orifice threads before installing into the brass elbow.
  - c) Install the new orifice(s) from the kit into the brass elbow.
6. Convert the pilot:
  - a) Pull the pilot hood straight up to access the pilot injector.
  - b) Using a 5/32" or 4 mm Allen key, remove the pilot injector.
  - c) Install the new pilot injector supplied with this conversion kit (Figure 9). Simply screw the new injector inside the pilot hood using the Allen key. Reinstall the hood by placing the hood on the assembly, line up the key way, and snap into place (Figure 10).

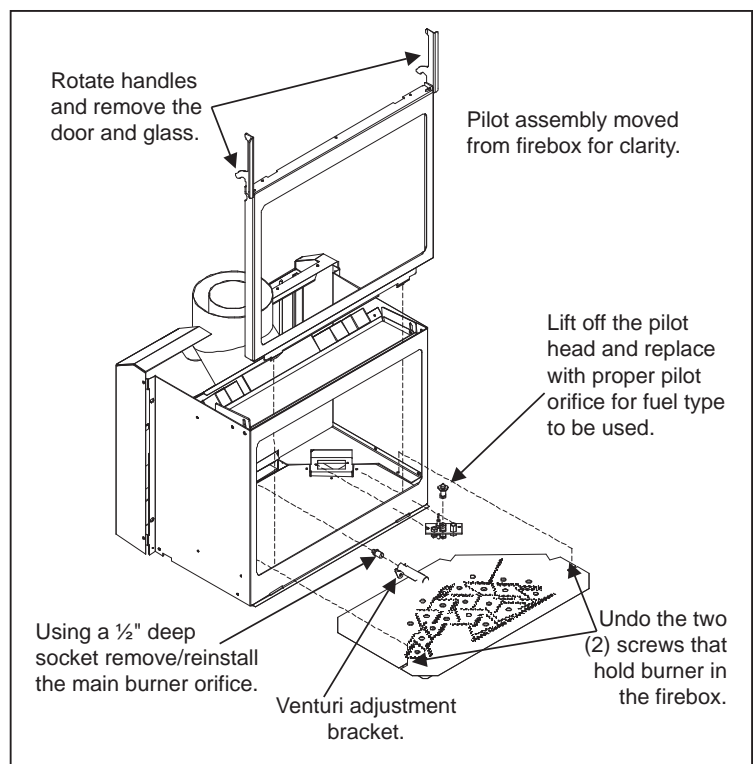

Figure 8: Unit burner shown apart.

# MAINTENANCE AND SERVICE

7. Convert the SIT gas valve:

- a) Remove the black protection cap from the HI/LO knob by hand shown in Figure 11.
  - b) Insert a  $5/32$ " or 4 mm Allen wrench into the hexagonal key-way of the screw (see Figure 12), rotate it counter-clockwise until it is free and extract it.
  - c) Check that the screw is clean and if necessary remove dirt.
  - d) Flip the screw (refer to Figure 13).
  - e) Using the Allen wrench as shown in Figure 12, rotate the screw clockwise until a torque of 9 inch lbs. **WARNING!** Do not over tighten the screw. It is recommended that you grip the wrench by the short side.
  - f) Verify that if the conversion is from NG to LPG, the screw must be re-assembled with the red o-ring visible (refer to Figure 14). If the conversion is from LPG to NG, the red o-ring of the screw must be not visible.
  - g) Re-attach the black protection cap that was removed in step a (Figure 11).
8. Reinstall the burner, brick panels, log set, embers, and glass door. Also refer to SECONDARY INSTALLATION - LOG SET AND EMBERS INSTALLATION. When re-installing the burner, ensure that the burner to pilot hood relationship is similar to what is shown in Figure 15. On some units you will need to pay special attention when installing the burner that the venturi adjustment rod is properly installed into the venturi adjustment piece welded to the burner venturi tube
  9. Reconnect the main gas line if it was disconnected and open the shut-off valve at the gas line to the unit.
  10. Use a small brush to apply a warm soapy water solution to all gas connections (use a half dish soap and half warm water). If a gas leak is present, bubbling will occur. Gas leaks can be repaired by using an approved pipe thread sealant or approved Teflon tape. NEVER USE AN OPEN FLAME WHEN TESTING FOR LEAKS.
  11. Reconnect the electrical power to the unit.



Figure 9: Pilot Orifice



Figure 10: Proper Pilot Position

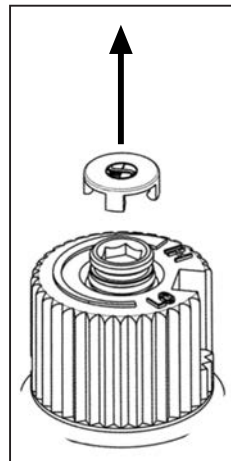

Figure 11: Removing valve cap.

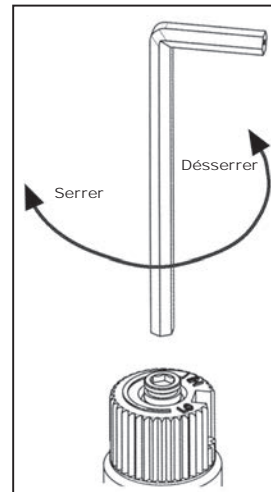

Figure 12: Removing valve screw.

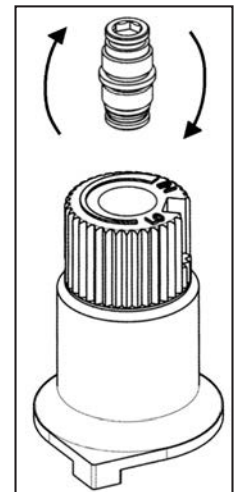

Figure 13: Flip valve screw.

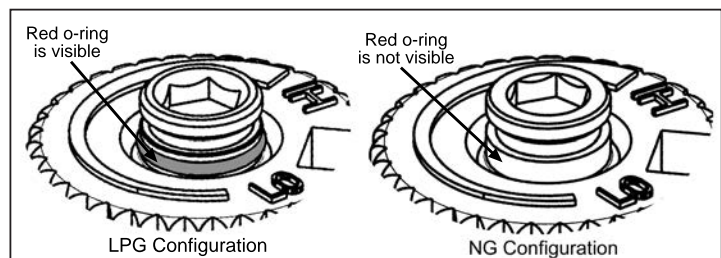

Figure 14: O-ring on valve screw.

## MAINTENANCE AND SERVICE

---

12. Relight the pilot and confirm the flame properly covers both the thermocouple and thermopile (see Figure 3). Should the pilot require adjustment, turn the adjustment screw (see Figure 48 on page 33) clockwise to increase or counterclockwise to decrease until the correct flame is achieved.
13. Relight the main burner in both the "HI" and "LO" positions to verify proper burner ignition, operation and proper flame appearance. Confirm the inlet and manifold pressures are within the acceptable ranges as directed in section INITIAL INSTALLATION - GAS LINE CONNECTION AND TESTING. If the Westport has been installed at an altitude higher than 2000ft (610m) it is required to de-rate the unit accordingly:

**In the USA:** The appliance may be installed at higher altitudes. Please refer to your American Gas Association guidelines which state: the sea level rated input of Gas Designed Appliances installed at elevations above 2000 (610 m) feet is to be reduced 4% for each 1000 feet (305 m) above sea level. Refer also to local authorities or codes which have jurisdiction in your area regarding the de-rate guidelines.

**In Canada:** When the appliance is installed at elevations above 4500 feet (1372 m), the certified high altitude rating shall be reduced at the rate of 4% for each additional 1000 feet (305 m).

14. MAKE SURE that the conversion label is installed on or close to the rating label to signify that the unit has been converted to a different fuel type.



**Figure 15: Ignitor assembly beside the burner.**

# INITIAL INSTALLATION

## QUALIFIED INSTALLERS ONLY

### WARNING:

Operation of this heater when not connected to a properly installed and maintained venting system can result in carbon monoxide (CO) poisoning and possible death.

### PREPARATION FOR INSTALLATION:

- Remove the packaging from the appliance, and check to make sure there is no damage. If damage is found, please report it to both the carrier and your dealer as soon as possible.
- Before beginning, carefully check the glass door and the log set
- Locate a position where the flue system of the stove can be properly installed without damaging the integrity of the building; e.g. cutting a wall or ceiling joist.
- Check stove and flue system clearance requirements.
- Locate the stove where it can be accessed by a gas supply line.
- Locate the stove in a large and open room that is centrally located in the house. This will optimize heat circulation and comfort.
- As the stove can be equipped with a convection fan, ensure that an electrical outlet is within 6 ft (1.8 m) of the stove.
- The flow of combustion and ventilation air must not be obstructed.

### CLEARANCES TO COMBUSTIBLES:

A. Sidewall to unit	11 inches (27.9 cm)
B. Backwall to unit	2.5 inches (6.35 cm)
C. Corner to unit	2.5 inches (6.35 cm)
D. Ceiling	60 inches above floor (152.4 cm)
E. Floor	(hard wood and linoleum) 0 inches

Note: When installing on a carpeted surfaces a non-combustible hearth pad must be used.

Minimum Alcove Dimensions:

Width	48 inches (121.9 cm)
Height	60 inches (152.4 cm)
Depth (max)	24 inches (60.96 cm)

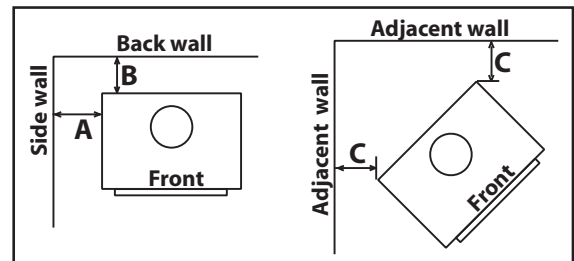

Figure 16: Clearances to combustibles.

**CLEARANCES MUST BE SUFFICIENT TO ALLOW ACCESS FOR MAINTENANCE AND SERVICE.**

### PLANNING YOUR INSTALLATION:

When planning your installation, it will be necessary to select the proper length of vent pipe for your particular requirements. It is important to note when passing through a wall, the maximum allowable wall thickness is 10 inches (25.4 cm), 1½ inches (3.8 cm) clearance to combustibles must be maintained. Select the amount of vertical rise desired for "vertical-to-horizontal" type installations. To determine the length of vent pipe required for vertical installations, measure the distance from the appliance flue outlet to the ceiling, the ceiling thickness, the vertical rise through the attic or second story, and allow for sufficient vent height above the roof line. For two story applications, a fire stop is required at each floor level. If an offset is needed in the attic, additional pipe and elbows will be required. To connect the venting system to the appliance flue outlet, a twist-lock adapter is built into the appliance at the factory. Refer to INITIAL INSTALLATION - VENT CONFIGURATION AND RESTRICTOR SETTINGS for venting parameters.



# INITIAL INSTALLATION

## QUALIFIED INSTALLERS ONLY

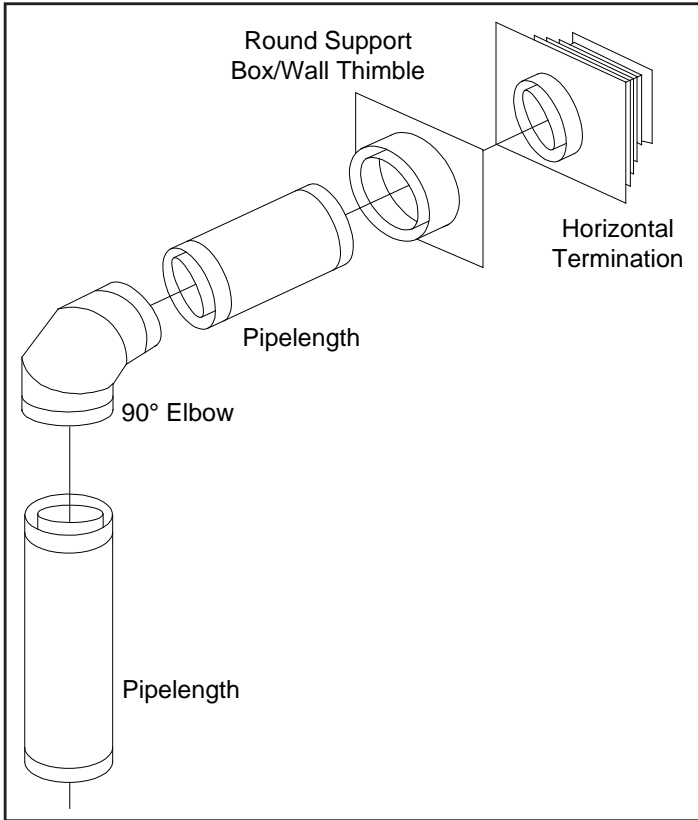

**Figure 17: Common Horizontal Installation.**

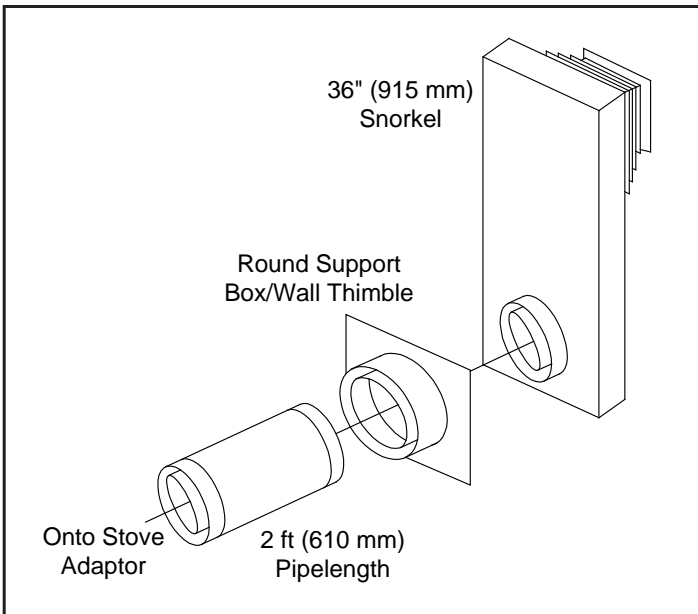

**Figure 19: Common Snorkel Installation.**

Your total vent pipe length must be within the shaded area of Figure 22 and Figure 23. If a 90° elbow is used in the horizontal plane, 36" (91.4 cm) must be subtracted from the allowable horizontal run.

There are three (3) basic types of Direct Vent System installations. The three (3) types of installations are shown in Figure 17 through Figure 19.

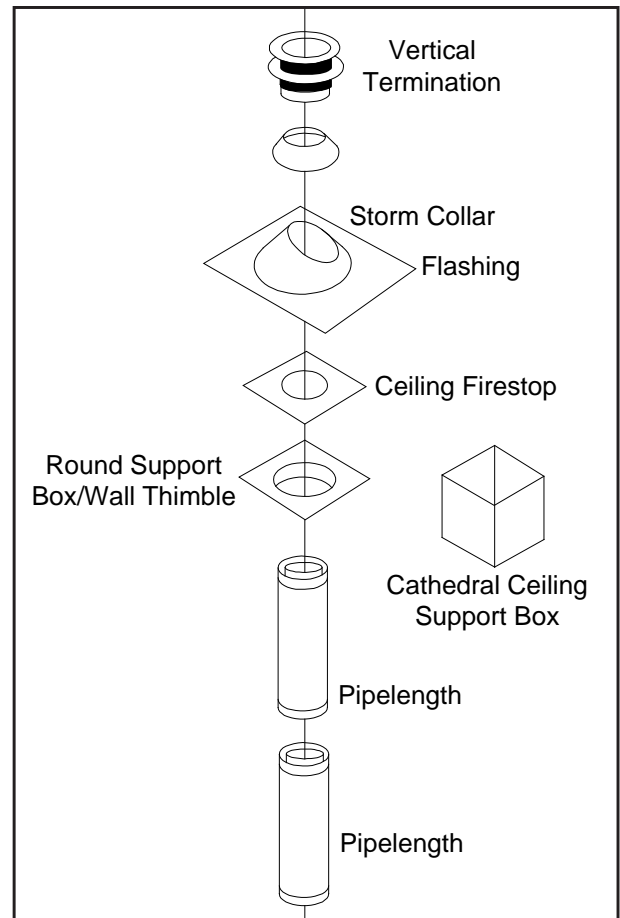
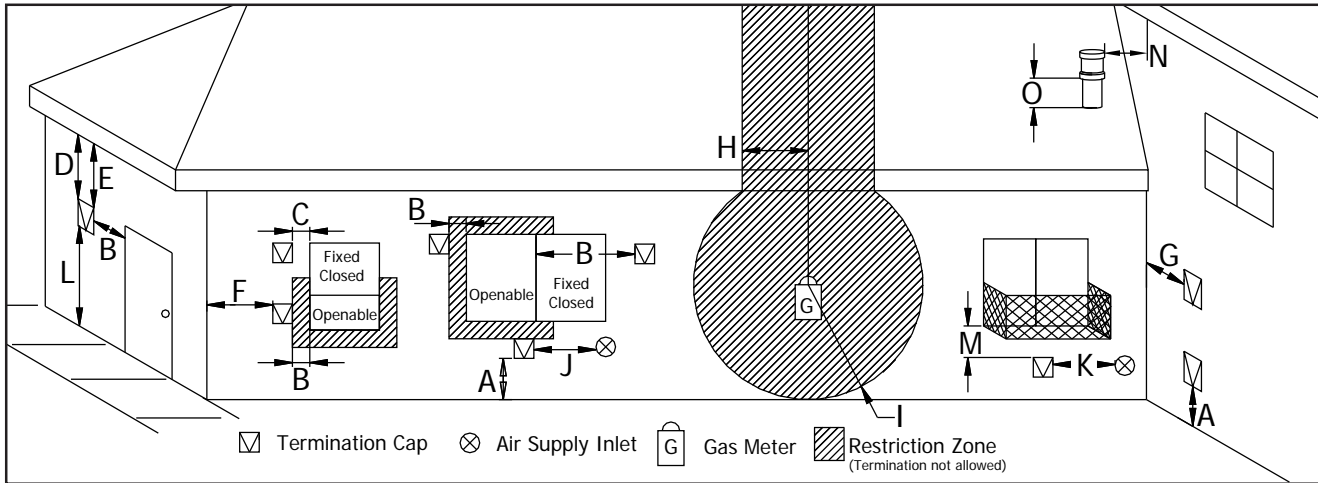

**Figure 18: Common Vertical Installation.**

# INITIAL INSTALLATION

## QUALIFIED INSTALLERS ONLY

### VENT TERMINATION RESTRICTIONS:



**Figure 20: Vent Termination Restrictions, refer to Table 3.**

**Table 3: Vent termination clearances, refer to Figure 20.**

Letter	Canadian Installation <sup>1</sup>	US Installation <sup>2</sup>	Description
A	12 in (30 cm)		Clearance above grade, verandah, porch, deck, or balcony.
B	12 in (30 cm)	9 in (23 cm)	Clearance from window or door that may be opened.
C	12 in (30 cm)*		Clearance from permanently closed window (to prevent condensation).
D	24 in (60 cm)*		Vertical clearance to ventilated soffit located above the terminal, within a horizontal distance of 2 ft (60 cm) from center line of terminal.
E	18 in (45 cm)*		Clearance to unventilated soffit.
F	12 in (30 cm)*		Clearance to outside corner.
G	12 in (30 cm)*		Clearance to inside corner.
H	3 ft (91 cm) within a height of 15 ft (4.5 m) above the meter/regulator assembly	3 ft (91 cm) within a height of 15 ft (4.5 m) above the meter/regulator assembly*	Clearance to each side of center line extended above meter/regulator assembly.
I	3 ft (91 cm)		Radial clearance around service regulator vent outlet.
J	12 in (30 cm)		Clearance to non-mechanical air supply inlet to building, or the combustion air inlet to any other appliance.
K	6 ft (1.83 m)		Clearance to mechanical air supply inlet.
L	7 ft (2.13 m) <sup>t</sup>		Clearance above paved sidewalk or paved driveway located on public property.
M	12 in / 30 cm <sup>+</sup>		Clearance under verandah, porch, deck, or balcony.
N	12 in (30 cm)*		Clearance horizontally to any surface (such as an exterior wall) for vertical terminations.
O	12 in (30 cm)		Clearance above roof line for vertical terminations.

<sup>1</sup> In accordance with the current CSA B149, Natural Gas and Propane Installation Code.

<sup>2</sup> In accordance with the current ANSI Z223.1 NFPA 54, National Fuel Gas Code.

\* These numbers are only estimates. Clearance in accordance with installation codes and the requirements of the gas supplier.

<sup>t</sup> A vent shall not terminate directly above a sidewalk or paved driveway that is located between two single family dwellings and it serves both dwellings.

<sup>+</sup> Permitted only if verandah, porch, deck, or balcony is fully open on a minimum of two sides beneath the floor.

**NOTE: Venting terminals shall not be recessed into walls or siding.**

# INITIAL INSTALLATION

## QUALIFIED INSTALLERS ONLY

**WARNING:** Do not mix parts from different vent manufacturers' systems.

**EXCEPTION TO WARNING:** This product has been evaluated by Intertek for using a DirectVent Pro starting collar in conjunction with other venting systems. Use of this system with the DirectVent Pro starting collar is deemed acceptable and does not affect the Intertek listing of the appliance.

**Table 4: Vent part numbers (Must state if galvanized or black wanted, PART NUMBERS).**

Direct Vent	Direct-Temp	DirectVent Pro	Description
4D7 (7")	4DT-06	46DVA-06	6" Pipe Length
<del> </del>	4DT-09	46DVA-09	9" Pipe Length
4D2	4DT-12	46DVA-12	12" Pipe Length
<del> </del>	4DT-18	46DVA-18	18" Pipe Length
<del> </del>	4DT-24	46DVA-24	24" Pipe Length
4D3	4DT-36	46DVA-36	36" Pipe Length
4D4	4DT-48	46DVA-48	48" Pipe Length
<del> </del>	<del> </del>	46DVA-60	60" Pipe Length
4D26A	4DT-TL14	46DVA-24TA	Adjustable Length
4D45L	4DT-EL45	46DVA-E45	45° elbow
4D90L	4DT-EL90S	46DVA-E90	90° elbow
4DHVS	4DT-VS	46DVA-VSS	Vinyl siding standoff/sheild
4DWT	4DT-WT	46DVA-WT	Wall thimble
4DSC	4DT-SC	46DVA-SC	Storm collar
4DFSP	4DT-FS	46DVA-WFS	Fire stop
4DWS	4DT-WS	46DVA-WS	Wall strap/support/band
4DF	4DT-AF6	46DVA-F6	Flashing, standard roof pitch
4DF12	4DT-AF12	46DVA-F7	Flashing, steep (up to 12/12) roof
<del> </del>	<del> </del>	46DVA-FF	Flat flashing
<del> </del>	<del> </del>	46DVA-VCH	High wind vertical termination
4DHCS	4DT-HC	46DVA-HC	High wind horizontal termination
<del> </del>	4DT-HKA / 4DT-HKB	46DVA-KHC	Horizontal termination kit
<del> </del>	4DT-CCKA	46DVA-KCA	Chimney Conversion Kit A
4DRCKA	4DT-CCKB	46DVA-KCB	Chimney Conversion Kit B
<del> </del>	<del> </del>	46DVA-KCC	Chimney Conversion Kit C

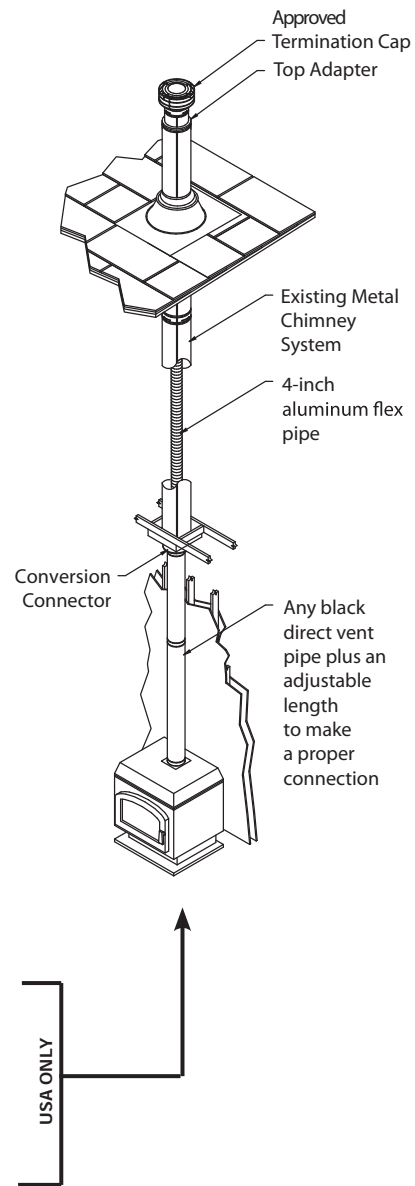

# INITIAL INSTALLATION

## QUALIFIED INSTALLERS ONLY

### VENT CONFIGURATIONS AND RESTRICTOR SETTINGS:

Figure 22 & Figure 23 show the range of venting options, they show possible vent configurations if the unit is top vented (see Figure 22) or rear vented (see Figure 23), for vertical and horizontal terminations, any layout that remains within the shaded area is acceptable. Having the fewest number of elbows is ideal, as they tend to disrupt air movement. Using 45° elbows is preferable to using 90° elbows. Also, a shorter vent system will perform better than a longer one.

The **ENVIRO WESTPORT** has been designed with a built in restrictor plate. The restrictor is designed to enhance flame appearance when installing this unit with vertical chimneys as well as installations with longer horizontal vent applications. It does this by controlling the amount of air moving through the vent pipe.

Figure 22 shows the vent restrictor position required, relative to the length of vent pipe. Longer vertical vent lengths necessitate greater restriction; position 1 is open and position 5 is maximum restriction (refer to Figure 21). To avoid injury, it is best to make this adjustment when the fireplace is cool or use welder's gloves or oven mitts.

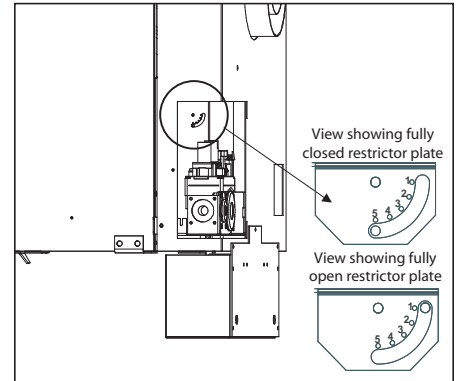

**Figure 21: Restrictor plate settings**

To access vent restrictor remove the valve cover plate from the right rear corner of the unit by undoing the two fastening screws.

Loosen the 1/4" hex head screw and adjust to the correct setting.

Slide the hex head screw to the next setting and re-tighten the screw to secure in place.

The numbers in this chart represent the actual vent restrictor settings. Although the numbers do not appear on the unit use this as a guide to follow.

Wait for unit to warm up to operating temperature to ensure proper and clean burning unit.

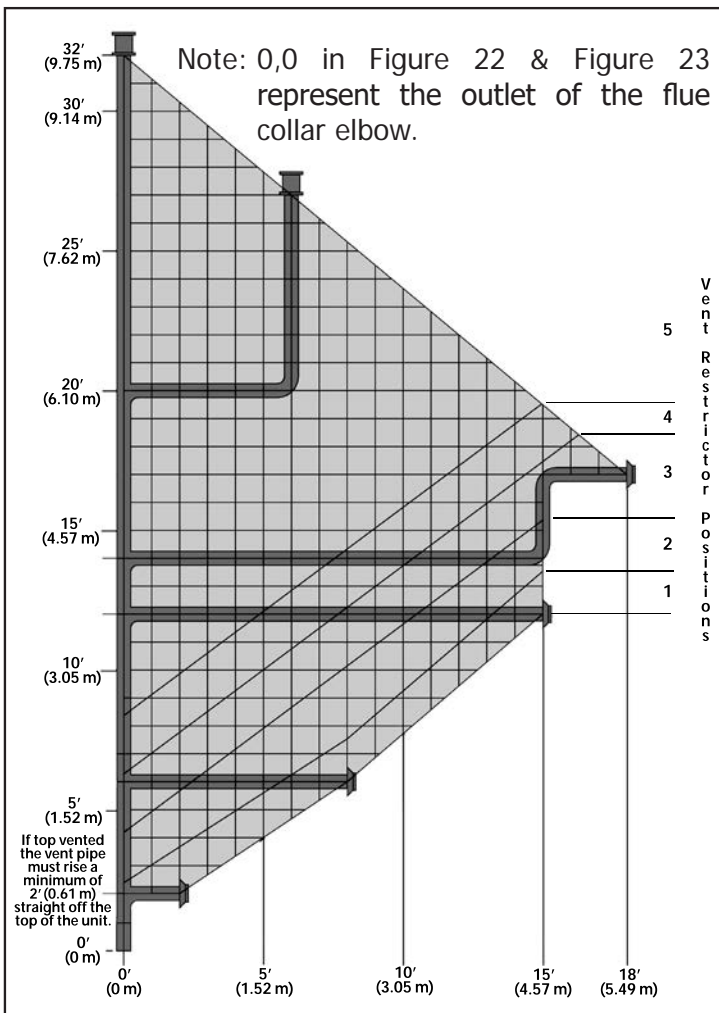

**Figure 22: Possible Vent Configurations for Top Venting; Vertical and Horizontal Terminations.**

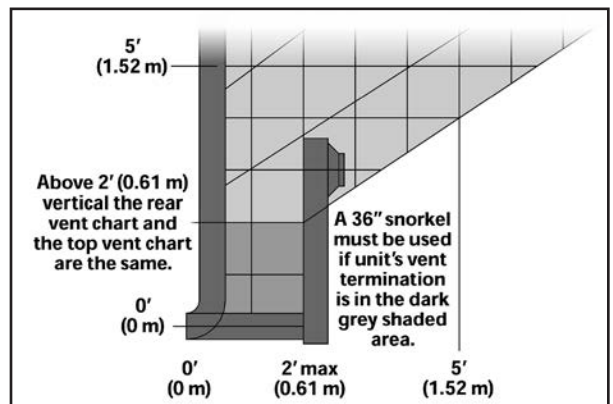

**Figure 23: Possible Vent Configurations for Rear Venting; Vertical and Horizontal Terminations.**

# INITIAL INSTALLATION

## QUALIFIED INSTALLERS ONLY

### HORIZONTAL INSTALLATION:

1. Set the appliance in the desired location. Check to determine if wall studs or roof rafters are in the way when the venting system is attached. If this is the case, you may want to adjust the location of the appliance.
2. Direct vent pipe and fittings are designed with special twist-lock connections. Assemble the desired combination of black pipe and elbows to the appliance adapter with pipe seams oriented towards the wall or floor, as much out of view as possible.

**Note:** Horizontal runs of vent pipe must be supported every 36" (915mm). Wall straps are available for this purpose, also when running horizontal pipe minimum clearances to combustibles must be maintained; **2" (51mm) at top, 1½" (38mm) at sides, 1½" (38mm) at bottom.**

3. With the pipe attached to the stove in the correct location, mark the wall for a 10" (25.4cm) x 10" (25.4 cm) square hole (refer to Figure 24). The center of the square hole should match the center line of the horizontal pipe. Cut and frame the 10" (25.4cm) x 10" (25.4cm) hole in the exterior wall where the vent will be terminated. Refer to Figure 20 and Table 3. If the wall being penetrated is constructed of non-combustible material i.e. masonry or concrete, a 7" (17.8cm) hole is acceptable.
4. Position the horizontal vent termination in the center of the 10" (25.4cm) x 10" (25.4cm) hole, and attach to the exterior wall with the four screws provided. Before attaching the vent termination to the exterior wall, run a bead of non-hardening mastic around the edges, so as to make a seal between the termination and the wall. The arrow on the vent termination should be pointing up, insure that the proper clearances to combustible materials are maintained.
5. Before connecting the horizontal run of the vent pipe to the vent termination, slide the black decorative wall thimble cover over the vent pipe.
6. Slide the appliance and vent assembly towards the wall, carefully inserting the vent pipe into the cap assembly. It is important that the vent pipe extend into the vent cap a sufficient distance with a minimum of 1¼" (3.2cm) overlap. Secure the connection between the vent cap pipe and the vent cap by attaching the two sheet metal straps extending from the vent cap assembly into the outer wall of the vent pipe. Use the two sheet metal screws provided to connect the straps to the vent pipe. Bend any remaining portion of the sheet metal straps back towards the vent cap, so the decorative wall thimble will conceal it (see left image in Figure 25).

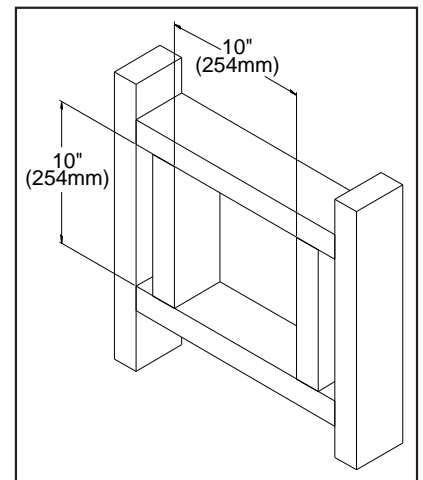

**Figure 24: Wall Framing Hole for Horizontal Installation.**

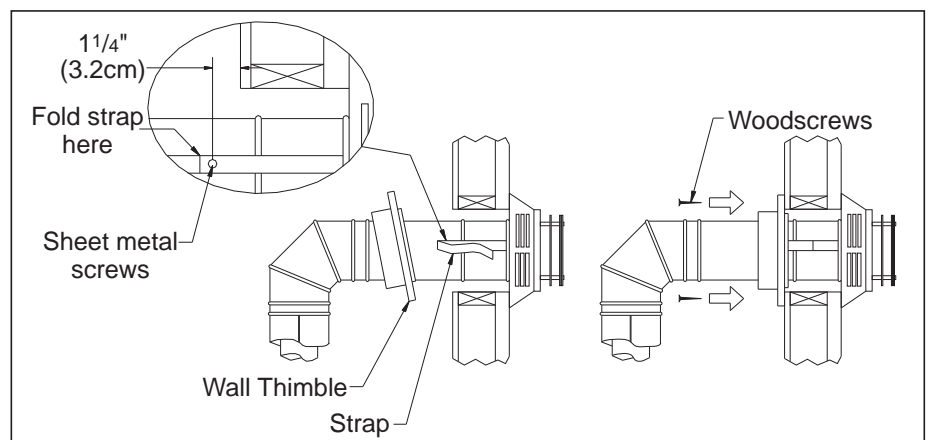

**Figure 25: Installing Decorative Wall Thimble.**

# INITIAL INSTALLATION

## QUALIFIED INSTALLERS ONLY

7. Slide the decorative wall thimble up to the wall surface and attach with the screws provided. Apply decorative brass or chrome trim if desired (see right image in Figure 25).

### NOTES:

- The four (4) wood screws provided should be replaced with the appropriate fasteners for stucco, brick, concrete, or other types of siding.
- For buildings with vinyl siding, a vinyl siding standoff, should be installed between the vent cap and the exterior wall (see Figure 26). Attach the vinyl siding standoff to the horizontal termination. The vinyl siding standoff prevents excessive heat from possibly melting the vinyl siding material. Note that the horizontal vent termination bolts onto the flat portion of the vinyl siding standoff (shaded area in Figure 26), so that an air space will exist between the wall and the vent termination.
- The horizontal run of vent pipe must be level and **should have a ¼ inch rise for every one foot of run towards the termination**. Never allow the vent to run downward. This could cause high temperature and may present the possibility of a fire.
- The location of the horizontal vent termination on the exterior wall must not be easily blocked or obstructed. Refer to INITIAL INSTALLATION - VENT CONFIGURATIONS AND RESTRICTOR SETTINGS.
- When installing a vent pipe in a chase the minimum clearance to combustibles is 2" (51 mm).
- Maintain manufacturer's clearances to combustibles with venting.

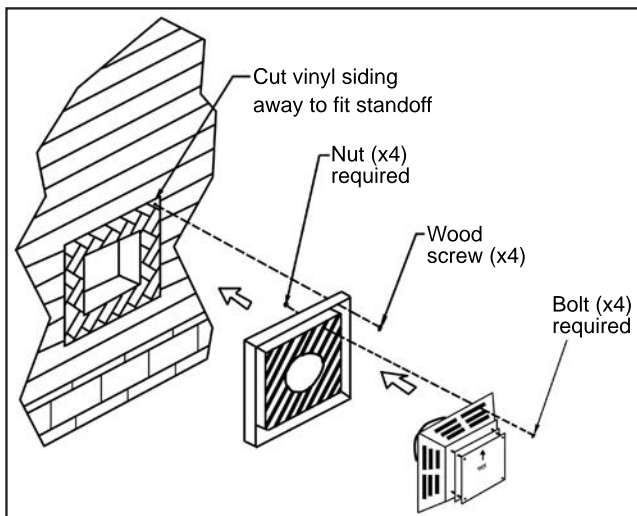

Figure 26: Installing Vent Cap with Vinyl Siding Stand-Off.

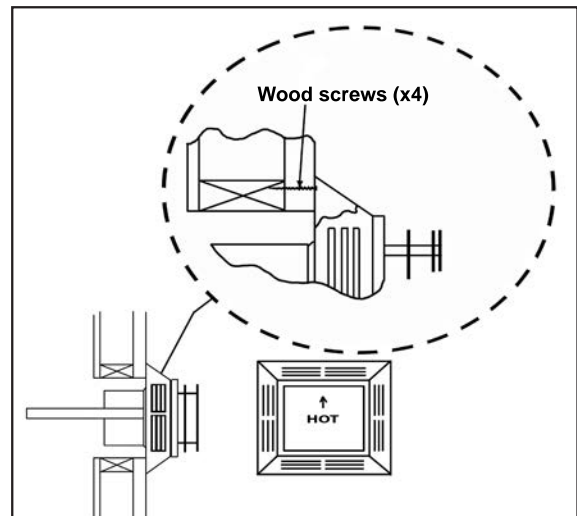

Figure 27: Installing Horizontal Vent Termination.

# INITIAL INSTALLATION

## QUALIFIED INSTALLERS ONLY

### VERTICAL INSTALLATION:

1. Check the instructions for required clearances (air spaces) to combustibles when passing through ceilings, walls, roofs, enclosures, attic rafters, or other nearby combustible surfaces. Do not pack air spaces with insulation.
2. Set the gas appliance in the desired location. Drop a plumb bob down from the ceiling to the position of the appliance flue exit, and mark the location where the vent will penetrate the ceiling. Drill a small hole at this point. Next, drop a plumb bob from the roof to the hole previously drilled in the ceiling, mark the spot where the vent will penetrate the roof. Determine if ceiling joists, roof rafters, or other framing will obstruct the venting system. You may wish to relocate the appliance, or to offset, to avoid cutting load bearing members.
3. To install the Round Support Box/Wall Thimble in a flat ceiling, cut a 10" square hole in the ceiling, centered in the hole drilled in Step 2. Frame the hole as shown in Figure 28.
4. Assemble the desired lengths of black pipe and elbows necessary to reach from the appliance adapter up through the Round Support Box. Insure that all pipe and elbow connections are in their fully twist-locked position.
5. Cut hole in the roof centered on the small hole placed in the roof from Step 2. The hole should be of sufficient size to meet minimum requirements for Clearance to Combustibles, as specified. Continue to assemble lengths of pipe and elbows necessary to reach from the ceiling support box up through the roof line. Galvanized pipe and elbows may be utilized in the attic, as well as above the roof line. The galvanized finish is desirable above the roof line, due to the higher corrosion resistance.

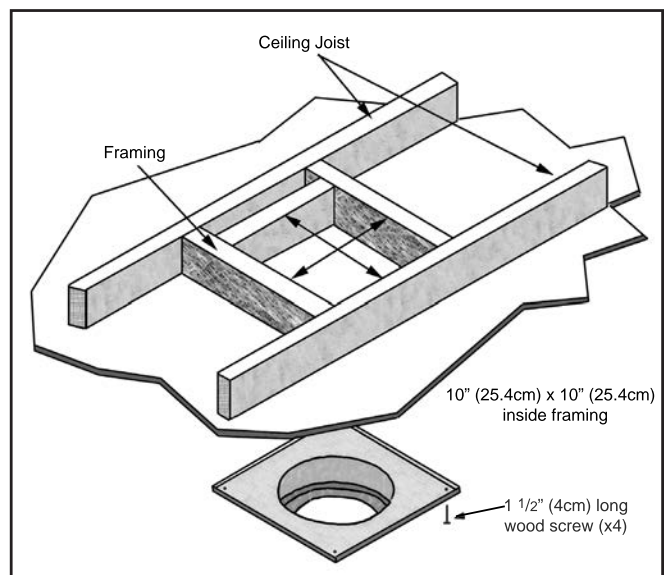

**Figure 28: Wall Framing for Hole for Vertical Installation.**

6. Once the pipe sections have been joined, and run up through the hole in the roof, slip an elbow strap over the exposed sections, bend the support straps outwards, and push the elbow strap down to the roof level, as shown in Figure 29. Tighten the clamp around the pipe section. Use a level to make sure the pipe is truly vertical. With roofing nails, secure the support straps to the roof. Seal the nails holes heads with non-hardening mastic. Trim the excess length of the support straps that extend out beyond the edge of the flashing.

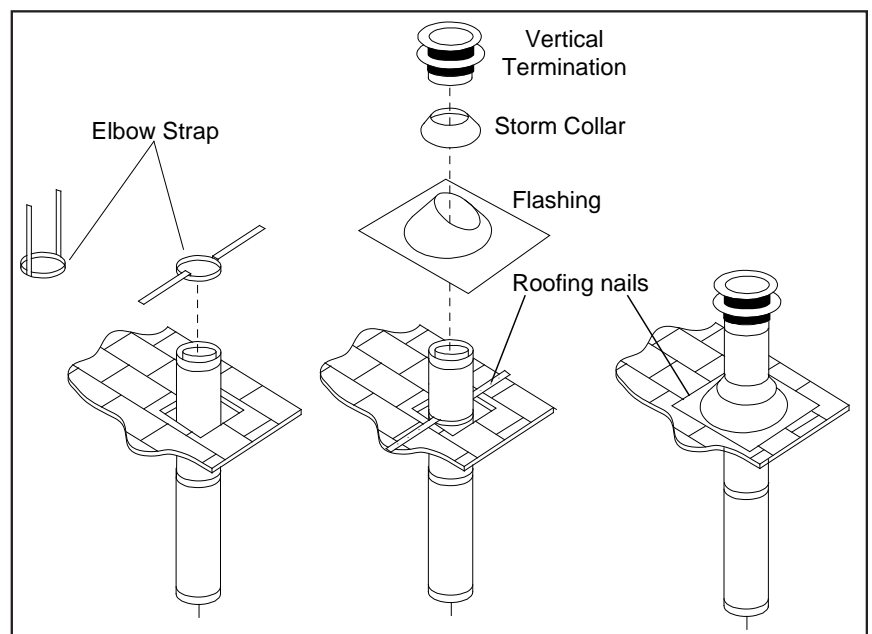
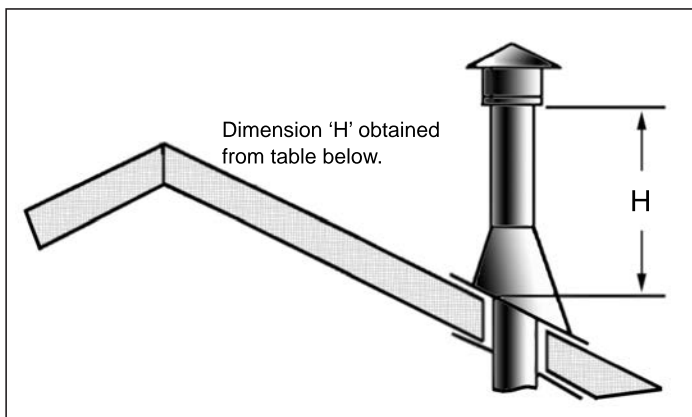

**Figure 29: Vertical Vent Termination Installation.**

# INITIAL INSTALLATION

## QUALIFIED INSTALLERS ONLY

7. Slip the flashing over the pipe section protruding through the roof. Secure the base of the flashing to the roof with roofing nails. Use a non-hardening sealant between the uphill edge of the flashing and the roof. Insure the roofing material overlaps the top edge of the flashing as shown in Figure 29. Verify that you have at least the minimum clearance to combustibles at the roof line.
8. Continue to add pipe sections until the height of the vent cap meets the minimum code requirements. Refer to Figure 30 and Table 5. Note that for steep roof pitches, the vent height must be increased. In high wind conditions, nearby trees, adjoining roof lines, steep pitched roofs, and other similar factors can result in poor draft, or down drafting. In these cases, increasing the vent height may solve the problem.
9. Slip the storm collar over the pipe, and push it down to the top of the roof flashing as shown in Figure 29. Use the non-hardening sealant around the joint between the pipe and the storm collar.
10. Twist-lock the vent cap.



**Figure 30: Height of Vertical Termination; Reference Table 5.**

**Table 5: Minimum 'H' for Figure 30**

Roof Pitch	Minimum Height	
	Feet	Meters
Flat to 7/12	1	0.3
Over 7/12 to 8/12	1.5	0.46
Over 8/12 to 9/12	2	0.61
Over 9/12 to 10/12	2.5	0.76
Over 10/12 to 11/12	3.25	0.99
Over 11/12 to 12/12	4	1.22
Over 12/12 to 14/12	5	1.52
Over 14/12 to 16/12	6	1.83
Over 16/12 to 18/12	7	2.13
Over 18/12 to 20/12	7.5	2.29
Over 20/12 to 21/12	8	2.44

### NOTES:

- (a) If an offset is necessary in the attic to avoid obstructions, it is important to support the vent pipe every 3 feet (91 cm), to avoid excessive stress on the elbows, and possible separation. Wall straps are available for this purpose (see Figure 31).
- (b) When ever possible, use 45° degree elbows instead of 90° degree elbows. The 45° degree elbow offers less restriction to the flow of flue gases and intake air.
- (c) For multi story installations. A ceiling firestop is required at the second floor, and any subsequent floors (see Figure 32). The opening should be framed to 10" (25.4 cm) x 10" (25.4 cm) inside dimensions, in the same manner as shown in Figure 28.
- (d) Any occupied areas above the first floor, including closets and storage spaces, which the vertical vent passes through, must be enclosed. The enclosure may be framed and sheet rocked with standard building materials. However consult the appliance manufactures installation instructions for the minimum allowable clearance between the outside of the vent pipe, and the combustible surfaces of the enclosure. Do not fill any required air spaces with insulation.



# INITIAL INSTALLATION

## QUALIFIED INSTALLERS ONLY

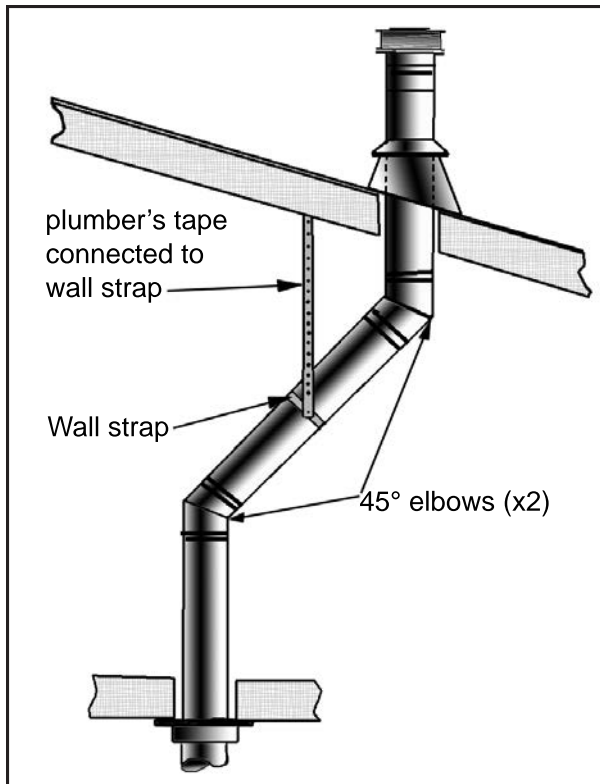

Figure 31: Use of Wall Straps

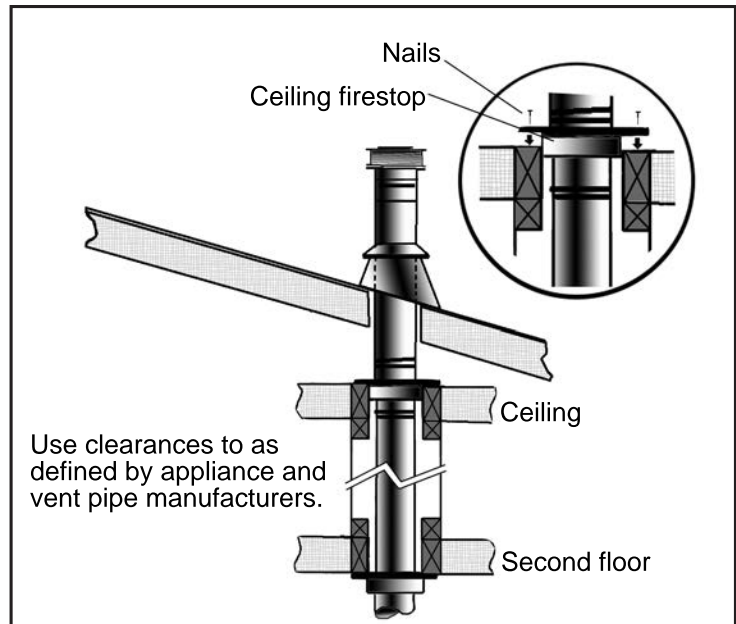

Figure 32: Multi-Story Vent Pipe Installation

### CATHEDRAL CEILING INSTALLATION:

1. Follow installation steps 1 & 2 under INITIAL INSTALLATION - VERTICAL INSTALLATION.
2. Using the plumb bob, mark the centerline of the venting system on the ceiling and drill a small hole through the ceiling and roof at this point. From the roof, locate the drill hole and mark the outline of the "Cathedral Ceiling Support Box".
3. Remove shingles or other roof coverings as necessary to cut the rectangular hole for the "Support Box". Cut the hole  $\frac{1}{8}$ " larger than the "Support Box" outline.
4. Lower the "Support Box" through the hole in the roof until the bottom of the "Support Box" protrudes at least 2 inches (5 cm) below the ceiling. Align the "Support Box" both vertically and horizontally with a level as shown in Figure 33. Temporarily tack the "Support Box" in the place through the inside walls and into the roof sheathing.

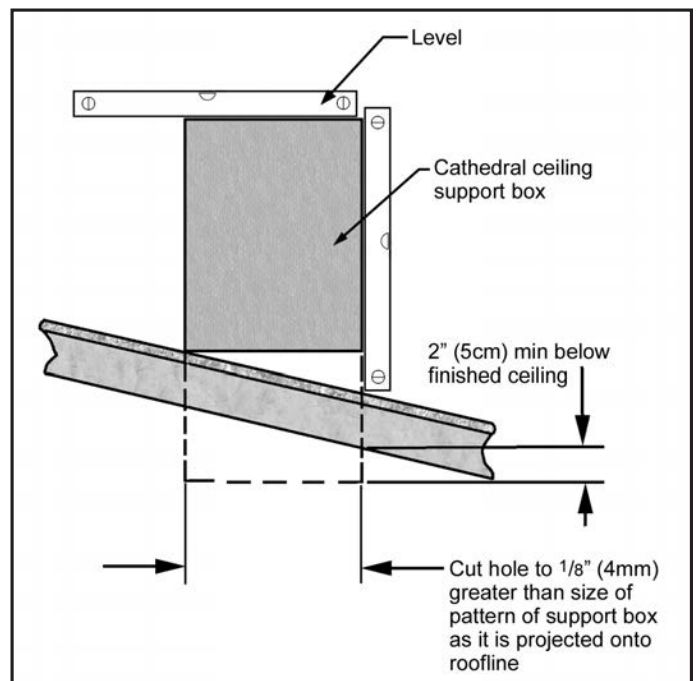

Figure 33: Cathedral Ceiling Support Box Leveling

# INITIAL INSTALLATION

## QUALIFIED INSTALLERS ONLY

- Using tin snips, cut the "Support Box" from the top corners down to the roof line, and fold the resulting flaps over the roof sheathing (Figure 34). Before nailing it in to the roof, run a bead of non-hardening mastic around the top edges of the "Support Box", to make a seal between the box and the roof. Clean out any combustible material from the inside of the "Support Box".
- Complete the cathedral ceiling installation by following the same procedures outlined in Steps 4 through 9 for INITIAL INSTALLATION - VERTICAL INSTALLATION.

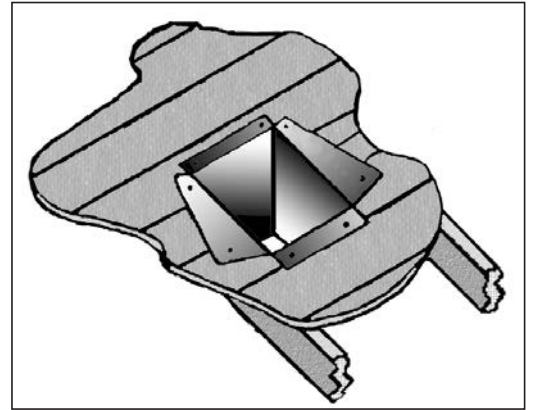

Figure 34: Cathedral Ceiling Support Box Installation.

### CORNER INSTALLATIONS:

Do not interfere with the structural integrity of the walls.

When rear venting if a 90° bend is used the maximum horizontal vent that can be used is 6" (152mm) and if a 45° bend is used the maximum horizontal vent that can be used is 12" (305mm). For installations with a 36" (915 mm) snorkel refer to Figure 35 and INITIAL INSTALLATION - VENT CONFIGURATIONS AND RESTRICTOR SETTINGS. For other corner installations refer to Figure 36 and INITIAL INSTALLATION - VENT CONFIGURATIONS AND RESTRICTOR SETTINGS.

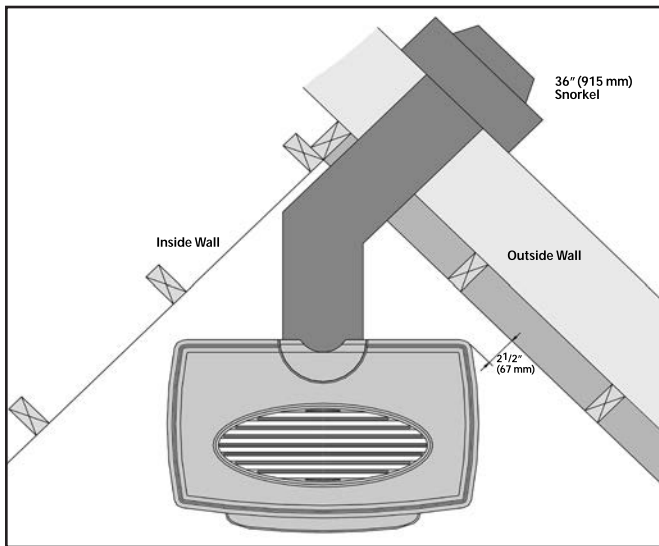

Figure 35: Corner installation rear vented with snorkel.

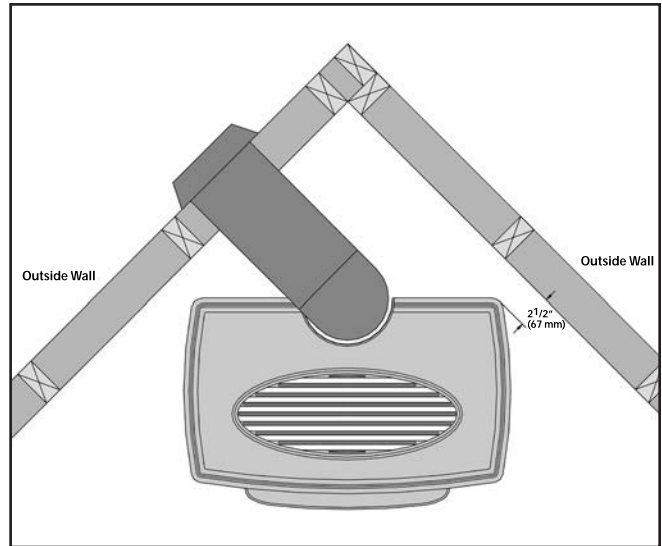

Figure 36: Corner installation top vented.

# INITIAL INSTALLATION

## QUALIFIED INSTALLERS ONLY

### **CONVERTING TOP VENTED INTO REAR VENTED:**

This unit has been shipped as a 30,000 Btu/hr top-vented freestanding unit. This unit can be converted to a rear vented unit with a 36" (915 mm) snorkel for some installation applications. To convert this unit to a rear vented model you must remove the flue pipe adapter and turn to the rear vent position. See sections INITIAL INSTALLATION - INSTALLATION OF REAR VENTED APPLIANCE.

1. Carefully remove the trivet and the stovetop. Place on a soft surface as not to damage the porcelain finishes (see Figure 37).
2. Remove the four (4) ¼" screws that hold the flue collar elbow to the unit body (see Figure 38).
3. Carefully remove the elbow being sure not to damage the gasket that is glued to the flue collar elbow, it seals the flue to the firebox.
4. Turn the elbow to the rear vent position and re-fasten with the screws removed in step 2 (see Figure 39).

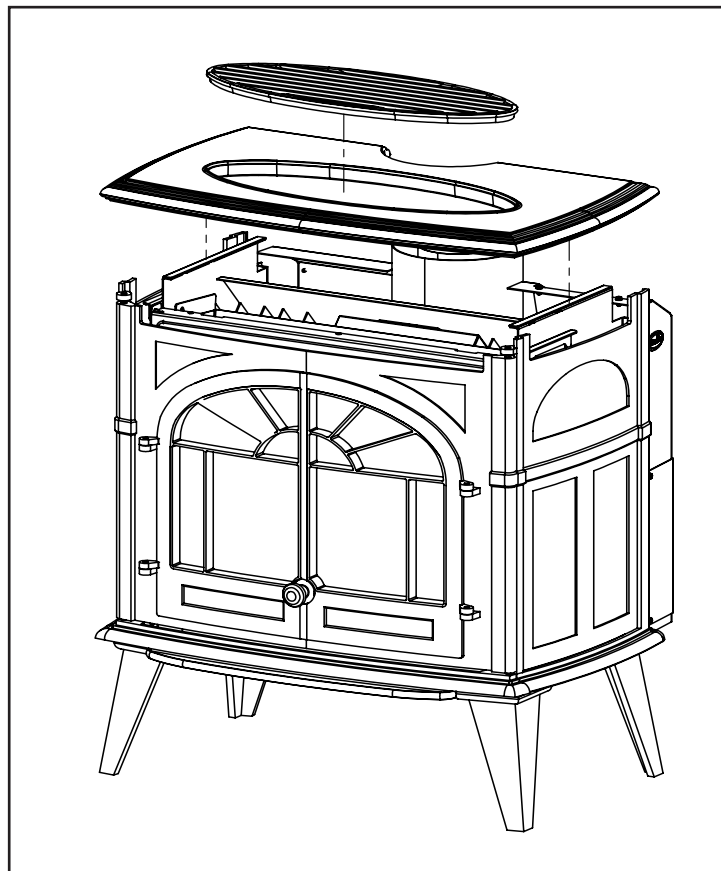

**Figure 37: Removal of Stove Top**

# INITIAL INSTALLATION

## QUALIFIED INSTALLERS ONLY

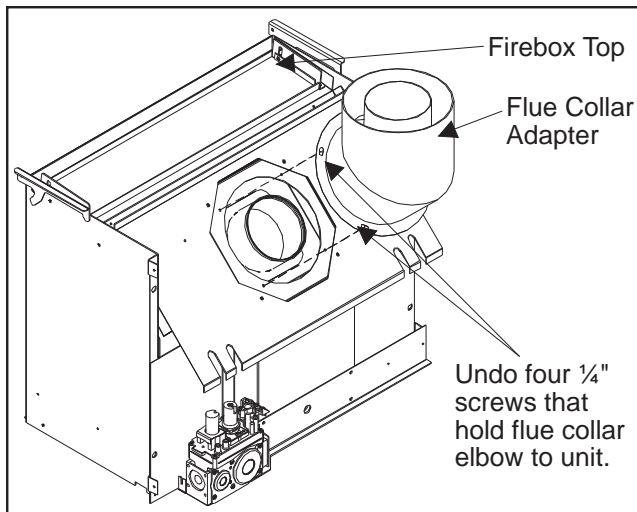

**Figure 38: Step 3 of Converting Top Vented into Rear Vented.**

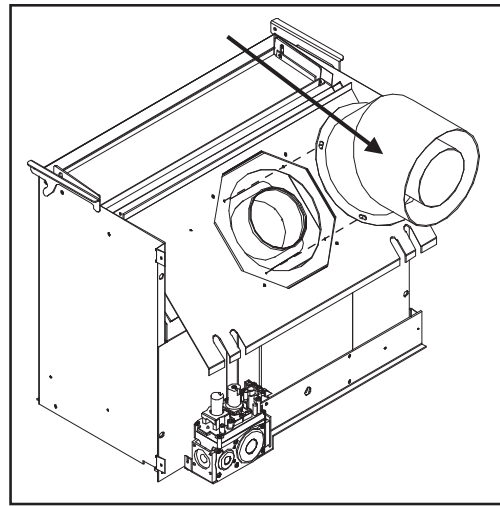

**Figure 39: Step 4 of Converting Top Vented into Rear Vented.**

### **INSTALLATION OF REAR VENTED APPLIANCE:**

Place the unit into position.

Attach a small section of pipe on the unit and mark exterior wall where vent would pass through the wall.

Cut a 10" (25.4 cm) minimum hole in the wall to maintain clearances to combustibles. Frame hole as shown in Figure 24.

Install a wall thimble.

Install interior finished collar.

Install the vent section through the wall.

**THIS UNIT MUST BE VENTED WITH A 36" (91 cm) SNORKEL KIT IF UNIT IS RATED FOR 30,000 Btu/hr NG and 26,000 Btu/hr LP.**

Seal around the vent terminal to the structure using a non hardening mastic.

Also refer to INITIAL INSTALLATION - VENT CONFIGURATIONS AND RESTRICTOR SETTINGS.

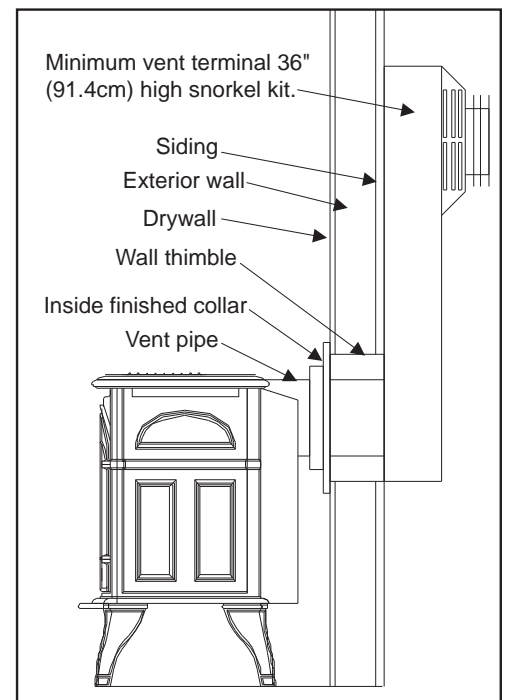

**Figure 40: Installation for Rear Vented; 30,000 Btu/hr.**

# INITIAL INSTALLATION

## QUALIFIED INSTALLERS ONLY

### INSTALLATION OF TOP VENTED; HORIZONTAL TERMINATION:

This is the most common type of installation style.

Set the unit in place.

Install a minimum 24" (61 cm) vertical chimney.

Install a 90° elbow, and mark the exterior wall where the vent would pass through.

Cut a 10" (25.4 cm) minimum hole in the wall to maintain clearances to combustibles around vent pipe. Frame hole if as shown in Figure 24.

Install wall thimble.

Install interior finished collar

Install the vent section through the wall and then install the vent termination.

Seal around the termination using a non hardening mastic.

### **CORNER INSTALLATION:**

This type of installation can be used in a corner installation. If a 90° elbow is used in the horizontal plane, 36" (91.4 cm) must be subtracted from the allowable horizontal run shown in Figure 22.

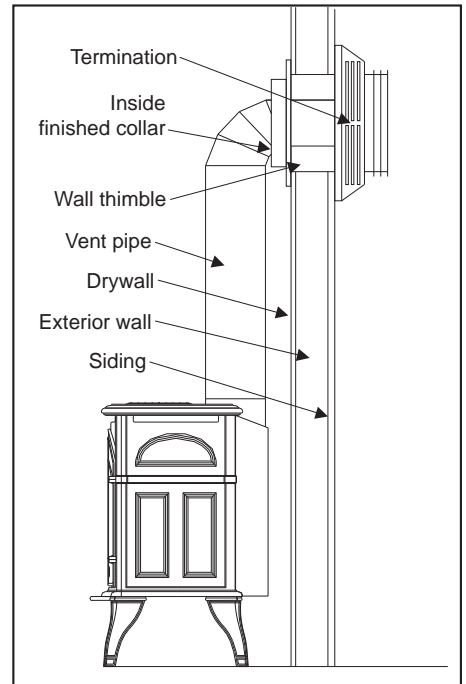

**Figure 41: Installation for Top Vented; Horizontal Termination.**

### INSTALLATION OF TOP VENTED; VERTICAL TERMINATION:

Place the unit in place.

Drop a plumb bob from the ceiling to the center point of the flue outlet.

Cut a 10" (25.4 cm) hole in the ceiling and the roof. Refer to Figure 28.

Install the ceiling support and insulation guard.

Install the roof flashing. Ensure that the roof flashing is installed under the roofing material so that a watertight seal is created.

Install the flue pipe from the top of the unit through the roof.

Ensure that all flue pipe and unit maintain required clearances to combustibles.

### **CORNER INSTALLATION:**

This type of installation can be used in a corner installation. If a 90° elbow is used in the horizontal plane, 36" (91.4 cm) must be subtracted from the allowable horizontal run shown in Figure 22.

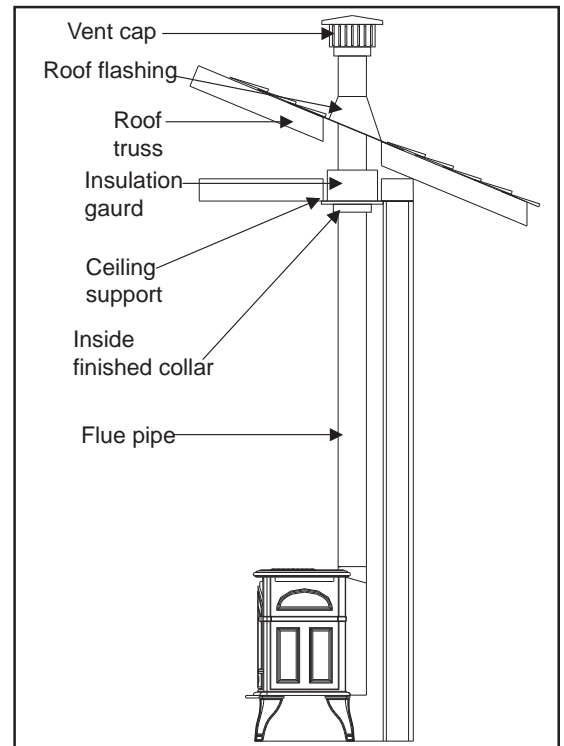

**Figure 42: Installation for Top Vented; Vertical Termination.**

# INITIAL INSTALLATION

## QUALIFIED INSTALLERS ONLY

### FREESTANDING DRAFTHOOD ADAPTOR - 50-841:

This Drafhhood Adaptor is a complete assembly and is ready to fit onto your Westport in a vertical vent application only. With the Drafhhood Adaptor correctly installed and wired to the gas control valve. Your Direct Vent Fireplace can be vented like a B-Vent Fireplace.

#### INSTALLATION:

**WARNING:** This Freestanding Drafhhood Adaptor must be fitted by a qualified service technician.

1. Remove the Drafhhood Adaptor from the packaging. Ensure the unit and wire harness are undamaged. If there is damage contact your dealer, distributor, or courier company before starting this installation.
2. Install the adaptor so the wires exit to the rear of the fireplace. Slide the Drafhhood Adaptor over the outlet pipe of the fireplace until the bottom of the adaptor collar stops on the top of the outlet. The Drafhhood Adaptor must be safely secured to the vent flanges with either self-tapping screws and/or high temperature sealant.

**WARNING:** During the fitting of the Drafhhood Adaptor, ensure that the wires are not pinched between the adaptor and the collar and/or flue outlet. Ensure that the opening of the Drafhhood Adaptor is not blocked or obstructed.

3. Being careful not to run any wiring tight across metal edges; connect them to the valve and "ON/OFF" switch (refer to Figure 43).
4. Adjust the restrictor plate to position 2.5 of 5. See the vent restrictor settings in the instruction manual.
5. Adjust the embers on the burner so they don't cover the burner ports.

#### WIRING DIAGRAM:

The fireplace connections are labelled in Figure 43. When installing the Drafhhood Adaptor onto a fireplace fitted with an optional wall switch or an optional thermostat, remove one wire

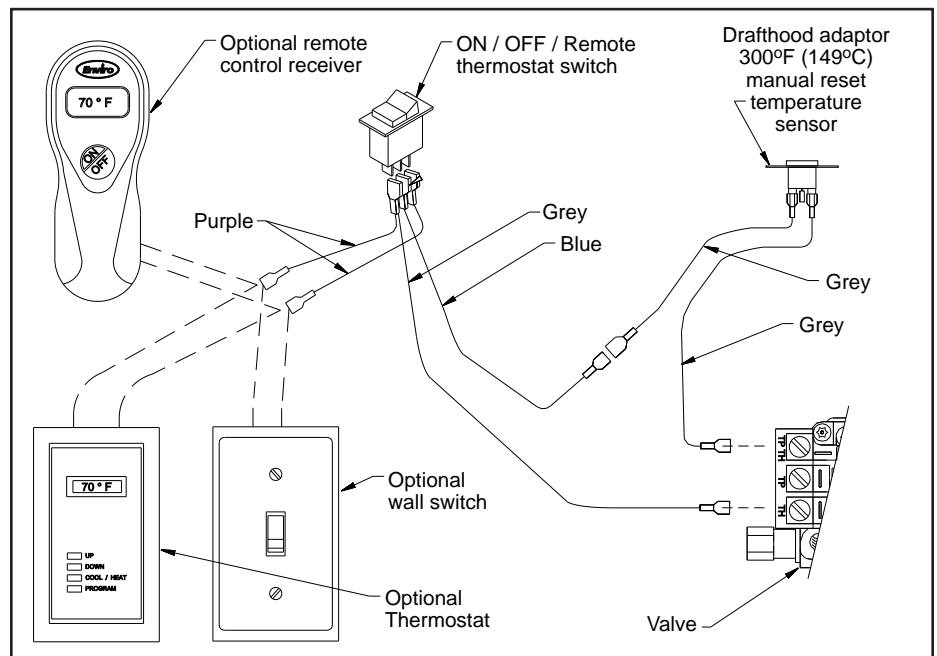

Figure 43: Wiring Diagram for Electrical Connection.

from the switch to the gas valve and connect the Drafhhood Adaptor harness as shown in Figure 43.

#### GENERAL VENTING INFORMATION:

##### Canadian Installations

The venting system must be installed in accordance with the current CSA B149 installation code and/or local codes having jurisdiction.

##### U.S.A. Installations

The venting system must be installed in accordance with the current National Fuel Gas Code, ANSI Z223.1, and/or local codes having jurisdiction.

# INITIAL INSTALLATION

## QUALIFIED INSTALLERS ONLY

The minimum clearance to combustibles is 6" (150 mm) when using single wall venting and 1" (25 mm) when using "B-vent" venting.

We strongly recommend installing an approved chimney liner in an existing brick chimney. This will maximize the potential draft of the chimney and lessen the effects of slow chimney start-up.

### VENTING OF A FIREPLACE FITTED WITH THE DRAFTHOOD ADAPTOR:

**Note:** Please refer to the chimney manufacturer's installation instructions prior to commencing the installation.

This unit may be vented to an existing masonry chimney, or where no masonry chimney is available, an approved "B-vent" chimney, or any other approved constructed chimney/vent system (see Figure 44 & Figure 45).

In either case, the fireplace may be connected to the chimney/vent using a 4" (10 cm) single wall vent connector.

When an existing masonry chimney is utilized for the venting, we recommend the vent connector be connected to an approved 4" (10 cm) diameter flue liner running the full height of the chimney. In many jurisdictions this flue liner may be mandatory.

If 4" (10 cm) single wall vent is used, a minimum of 6" (15 cm) must be maintained between the vent connector and any combustibles.

If 4" (10 cm) "B-vent" is used a minimum of 1" (25 mm) must be maintained between the vent connector and any combustibles.

**CAUTION:** A minimum vent height of 12' (3.6 m) from the floor is required to effectively vent this fireplace.

### SPILLAGE TEST:

A spillage test must be performed prior to leaving the installed fireplace with the customer. Perform this test in the following manner:

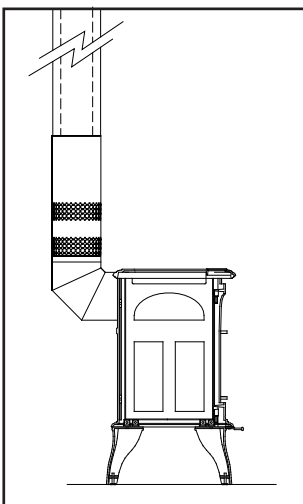

Figure 45: Unit rear venting style.

1. Close all windows and doors in the room.
2. Start all exhaust fans in the house and the furnace blower.
3. Light the fireplace and set to maximum flame adjustment.
4. After a minimum of 10 minutes operation, test the chimney draft with a smoke match at the top row of the pattern to confirm that there is adequate draft or 'pull' at the openings around the body of the Drafhoad Adaptor, as shown in Figure 46.

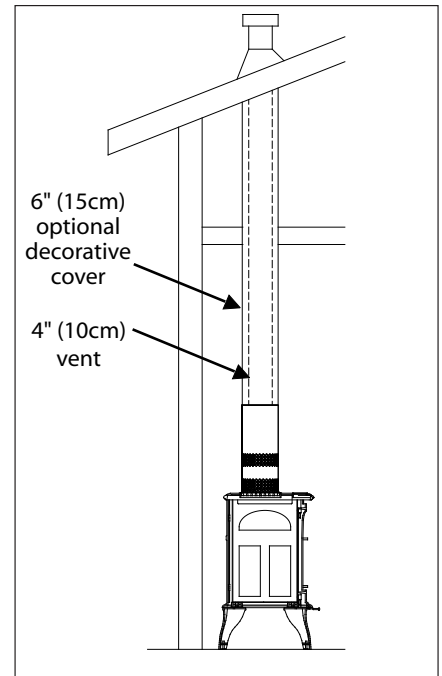

Figure 44: Unit top venting styles

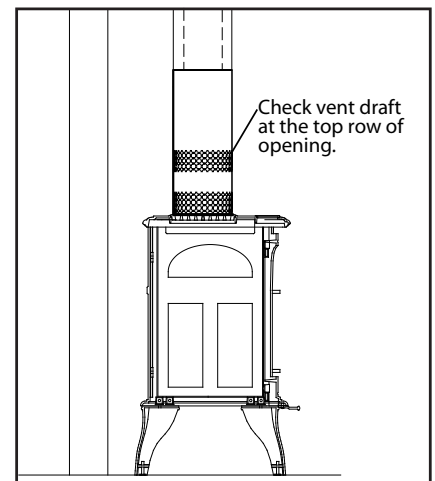

Figure 46: Draft test place.

# INITIAL INSTALLATION

## QUALIFIED INSTALLERS ONLY

### AUTOMATIC SAFETY SHUT DOWN:

If the spill switch is activated and shuts off the main burner the following procedure should be followed.

- Is the pilot flame still on? **If not, the reason for the fireplace shut down is not the spill switch.**
- Turn off the pilot flame and turn off all controls. Let fireplace to cool down.
- Check for blockages or restrictions in the flue and venting components.
- Restart the fireplace and check for vent draft as described earlier.
- Operate the fireplace in a normal manner.
- If the main burner shuts down again after a period of operation, turn off the fireplace and contact your service technician.

### SPILL SWITCH REPLACEMENT:

Use the following instructions to replace the Safety Spill Switch.

1. Turn the unit off and allow it to cool.
2. Disconnect the spill switch wires from the valve and on/off/remote rocker switch wire (see Figure 43).
3. Remove the four mounting screws holding the spill switch bracket and remove the bracket (see Figure 47).
4. Remove and replace the spill switch with a 50-885 Spill Switch Assembly using a T-20 torx type driver.
5. Follow the reverse of the previous steps.



Figure 47: Spill switch installation.

### OPTIONAL FINISHING:

In installations where the flue connector is running from the draffhood into a non-combustible chimney the following optional finishing technique can be used.

**CAUTION: Installations where the flue connector or venting connects to, or passes through, combustible walls or ceilings, the inner vent components must be 'B-vent'. It is not allowable in these applications to use single wall inner vent components.**

For decorative purposes a 6" (15 cm) single wall black stove pipe may be installed over the 4" (10 cm) single wall or 'B-Vent'.

**Note: The use of these components is for aesthetic purposes only and does not effect the fact that the fireplace, when fitted with the Draffhood Adaptor, is a Natural Vent appliance and therefore draws air in through the Draffhood Adaptor intake ports.**



# INITIAL INSTALLATION

## QUALIFIED INSTALLERS ONLY

### GAS LINE CONNECTION AND TESTING:

**WARNING:** Only persons licensed to work with gas piping may make the necessary gas connections to this appliance.

### GAS LINE CONNECTION

- This stove is equipped with a certified flexible pipe located on the right side of the unit terminating in a  $\frac{3}{8}$ " male NPT fitting. Consult your local authorities codes or the CAN/CGA B 149 (1 or 2) installation code in Canada, or in the USA gas installations follow either local codes or the current edition of the National Fuel Gas Code ANSI Z223.1.

- The efficiency rating of this appliance is a product thermal efficiency rating determined under continuous operating conditions and was determined independently of any installed system.

The appliance and its shutoff valves must be disconnected from the gas supply piping system during any pressure testing where the pressure exceeds  $\frac{1}{2}$  PSIG (3.45 KPa) or damage will occur to the valve.

The appliance must be isolated from the gas supply piping system by closing its individual manual shutoff valve during any pressure testing of the gas supply piping system at test pressures equal to or less than  $\frac{1}{2}$  psig (3.45 KPa).

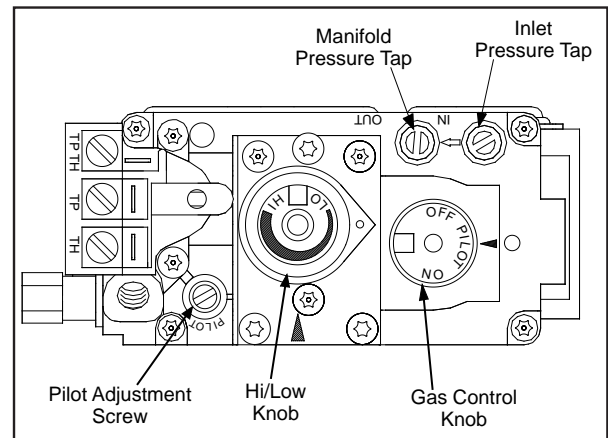

**Figure 48: Fully Labeled Gas Valve**

**Always check for gas leaks with a soap and water solution after completing the required pressure test.**

### TO TEST VALVE PRESSURES

The pressure taps are located on the left side of the valve

- Turn set screw 1 turn counter clockwise to loosen,
- Place  $\frac{5}{16}$ " (8 mm) I.D. hose over pressure tap system.
- Check pressures using a manometer.
- When finished, release pressure, remove hose & tighten set screw.

**Table 6: Pressure and BTU Information**

	Natural Gas	Propane
<b>Main Burner</b>	#39 DMS	#53 DMS
<b>Manifold Pressure</b>	3.8" W.C. / 0.95KPa	11.0" W.C. / 2.7KPa
<b>Min. Manifold Pressure</b>	1.1" W.C. / 0.27KPa	2.7" W.C. / 0.67KPa
<b>Max Supply Pressure</b>	7.0" W.C. / 1.74KPa	13.0" W.C. / 3.28KPa
<b>Min. Supply Pressure</b>	5" W.C. / 1.24KPa	12.0" W.C. / 2.98KPa
<b>Max BTU/hr Input</b>	30,000 BTU/hr (8.80KW)	26,500 BTU/hr (7.76KW)
<b>Min. BTU/hr Input</b>	17,000 BTU/hr (4.98 KW)	14,000 BTU/hr (4.10KW)
<b>Venturi Setting</b>	$\frac{1}{16}$ " min.	$\frac{3}{16}$ " min.

**NEVER USE AN OPEN FLAME FOR LEAK TESTING.**

# INITIAL INSTALLATION

## QUALIFIED INSTALLERS ONLY

### ELECTRICAL REQUIREMENTS FOR GAS VALVE AND OPTIONAL BLOWER:

The **ENVIRO WESTPORT** will operate without electrical power. This model has a millivolt gas control, which uses the pilot flame to generate enough electricity to operate the main burners. The appliance when equipped with an optional blower must be electrically connected and grounded in accordance with local codes or in the absence of local codes, with the current CSA C22.1 CANADIAN ELECTRICAL CODE Part 1, SAFETY STANDARDS FOR ELECTRICAL INSTALLATIONS, OR THE NATIONAL ELECTRICAL CODE ANSI / NFPA 70 in the U.S.

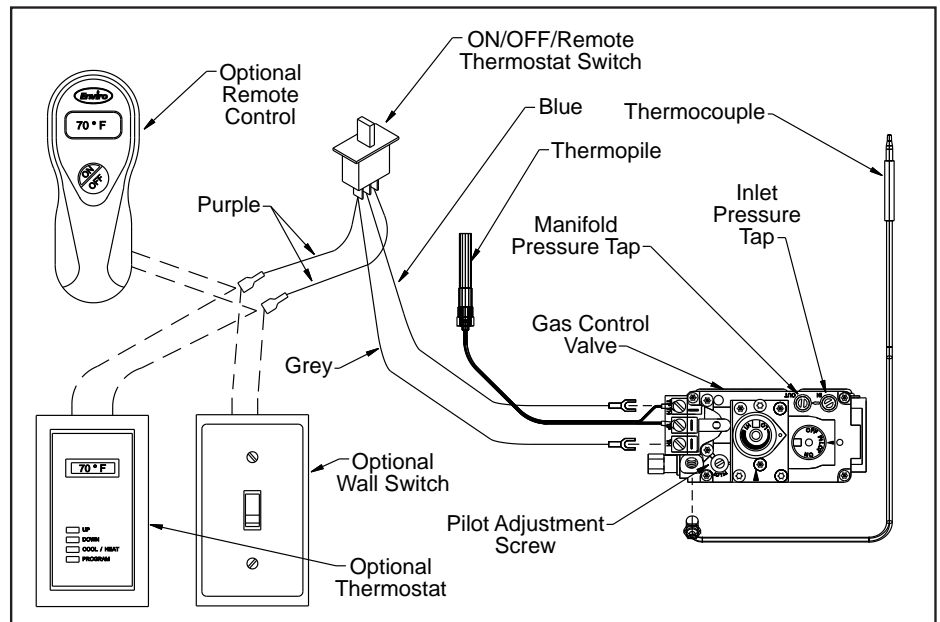

Figure 49: Gas Control Valve and Optional Thermostat Wiring.

Table 7: Recommended Thermostat Wire Size

Wire Size	Max. Length
14 gauge	100 ft (30.48 m)
16 gauge	60 ft (18.29 m)
18 gauge	40 ft (12.00 m)
20 gauge	25 ft (7.62 m)
22 gauge	18 ft (5.49 m)

**CAUTION:** Label all wires prior to disconnection when servicing controls. Wiring errors can cause improper and dangerous operation. Verify proper operation after servicing.

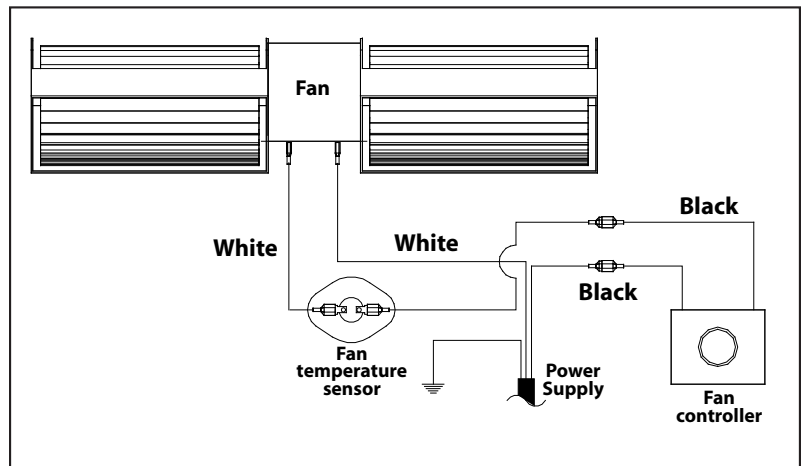

Figure 50: Wiring Diagram For Fan Control.

**WARNING:** Electrical grounding instructions. This appliance is equipped with a three-prong (grounding) plug for your protection against shock hazard, and must be plugged directly into a properly grounded three-prong outlet.

**DO NOT** cut or remove the grounding prong from this plug.

# SECONDARY INSTALLATION

## INSTALLATION OF OPTIONAL BLOWER:

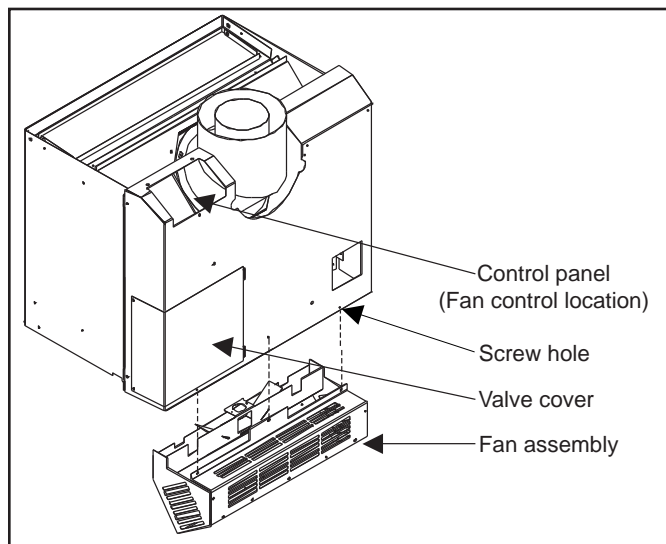

**Figure 51: Optional Blower (Fan) Installation**

1. Remove the pre-assembled blower from the packaging. Inspect the blower for damage. If damage is noticed call your dealer, distributor or courier company and have components replaced.
2. Ensure the temperature sensor will touch the unit when mounted. If it does not touch, adjust the sensor so it does.
2. Place the fan assembly behind the unit and secure with the three screws provided, (as shown in Figure 51).
3. Open the gas valve cover. Carefully cut the decal portion on the control panel and install the fan control switch in this location. See Figure 50 for wiring of optional blower.
4. Plug the fan assembly into the wall outlet and turn the unit on to ensure fan operation.

## INSTALLATION OF LOG SET AND EMBERS:

The placement of the logs is not arbitrary. If they are positioned incorrectly, the flames can be “pinched” and will not burn correctly. The burner come with four (4) locator pins, and the right log has two (2) ledges which make alignment easier. Using the pictures provided, carefully set the logs in place.

**NOTE: The logs are fragile and should be handled gently.**

**CAUTION:** Use only the type of ember material supplied with this appliance. Due to the irregular size of the ember material there may be more than required. The use of other foreign materials on the burners may create dangerous conditions.

If over time, through cleaning and servicing, these embers require replacement, contact the nearest ENVIRO dealer for replacement embers.

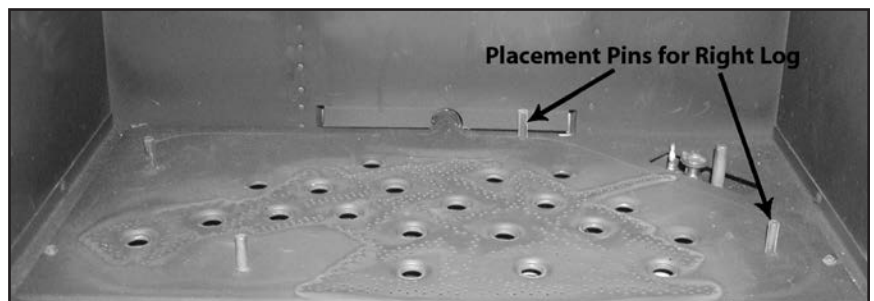

**Figure 52: Step 1 of Log Placement.**

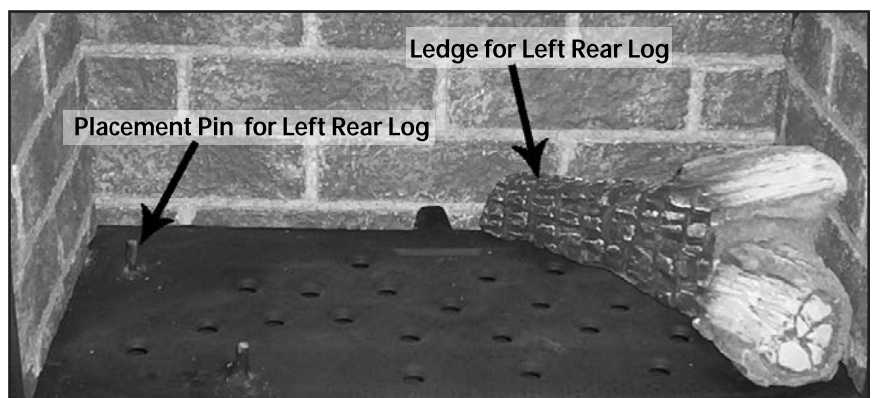

**Figure 53: Step 2 of Log Placement.**

## SECONDARY INSTALLATION

1. Carefully remove logs from box. Check to ensure there is no damage. It is very important to install all logs in their proper position to insure safe, optimum operating conditions.

2. Place the log set into the firebox. Locate each log by seating it down onto the burner tray support pins. Follow Figure 52 to Figure 59

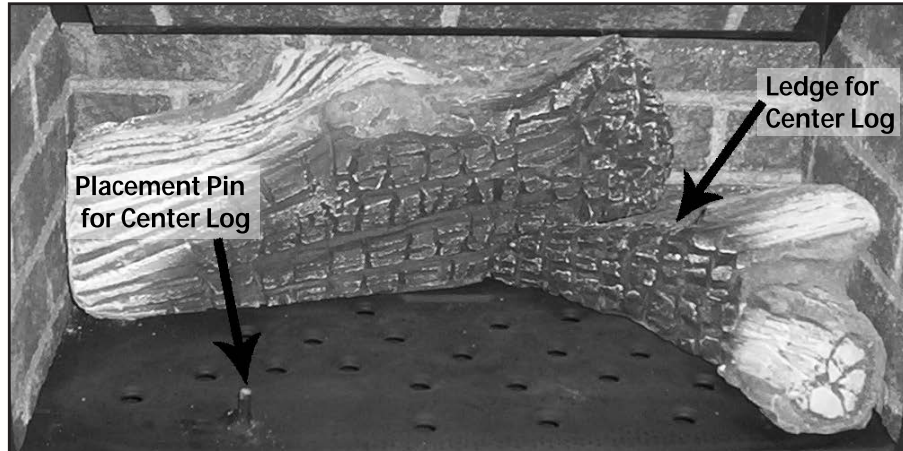

Figure 54: Step 3 of Log Placement.

3. A bag of ceramic fiber embers and rock wool embers is provided gently remove the ember material from the plastic bag. Spread a layer loosely in a random manner across the burner tray. Do not allow any embers to rest against pilot assembly. (See diagram provided for proper ember placement.)

**DO NOT** pack this ember material as this could create an unsafe condition, leave embers loose.

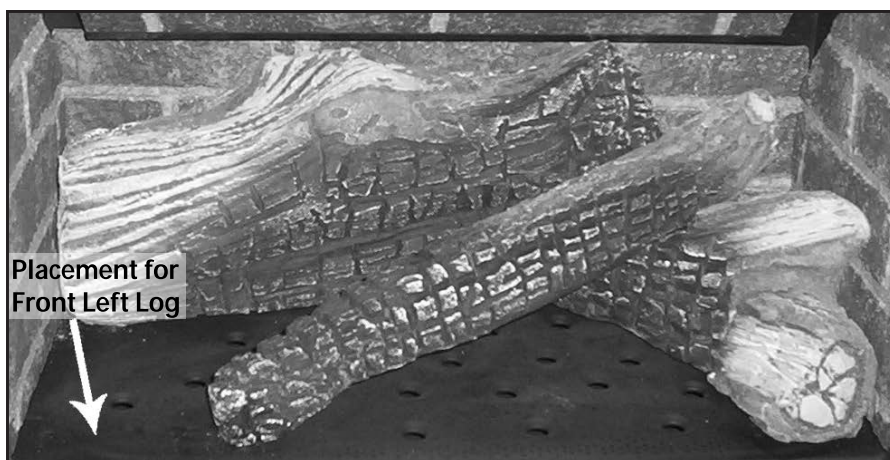

Figure 55: Step 4 of Log Placement.

4. Upon the first light up, watch for ignition to **ALL** burner ports. If a long delay is noted: First, wait for the appliance to cool down.

- Open the front door of the appliance.
- Check to carefully reposition the embers making sure that burner ports are not plugged solid or blocked.

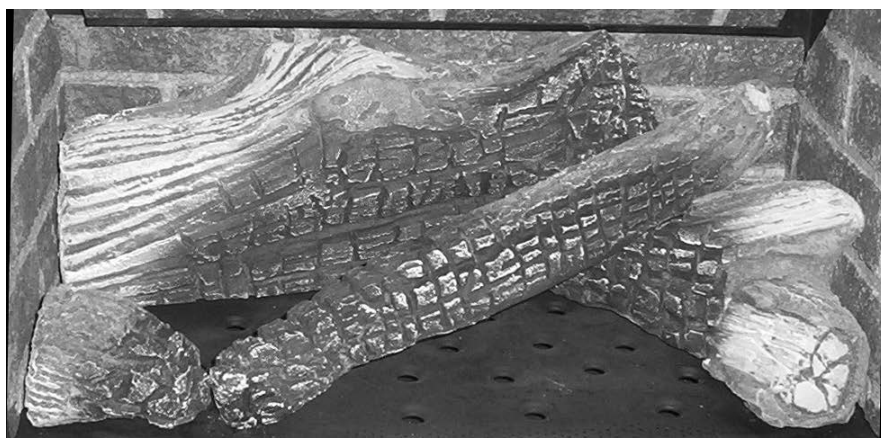

Figure 56: Complete Log Placement.

## SECONDARY INSTALLATION

**Important note:** When the unit is turned on for the first time, It should be turned onto high without the fan on for the first four (4) hours. This will cure the paint, logs, gasket material and the other products used in the manufacturing process. It is advisable to open a window or door, as the unit will start to smoke and can irritate some people. After the unit has gone through the first burn turn the unit off including the pilot, let the unit get cold then remove the glass door and clean it with a good gas fireplace glass cleaner, available at your local ENVIRO dealer.

See MAINTENANCE AND SERVICE on how to remove door to clean glass.



**Figure 57: Log Placement with Rock Wool.**



**Figure 58: Log Placement with Rock Wool & Embers.**



**Figure 59: Appliance Burning.**

**CAUTION: NEVER OPERATE THIS APPLIANCE WITH THE GLASS DOOR REMOVED.**

# SECONDARY INSTALLATION

## INSTALLATION OF PANEL SET:

Do not install when the unit is hot.

The brick panel set is fragile. Handle panels with care and avoid knocking them on the placement pins or any other object.

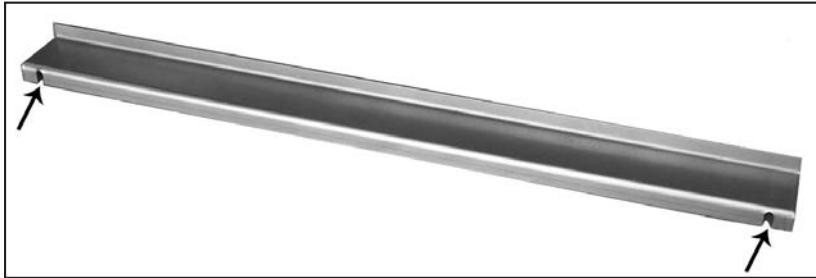

Figure 60: Brick panel bracket, slots shown.

1. Remove the two (2) screws from the rear of the baffle, use a  $\frac{1}{4}$ " socket or a flat head screwdriver. Place the provided brick bracket (Figure 60) at the rear of the baffle with the slots over the screw holes (see Figure 60). Insert two (2) of the provided screws into the two (2) holes along the bottom of the baffle.

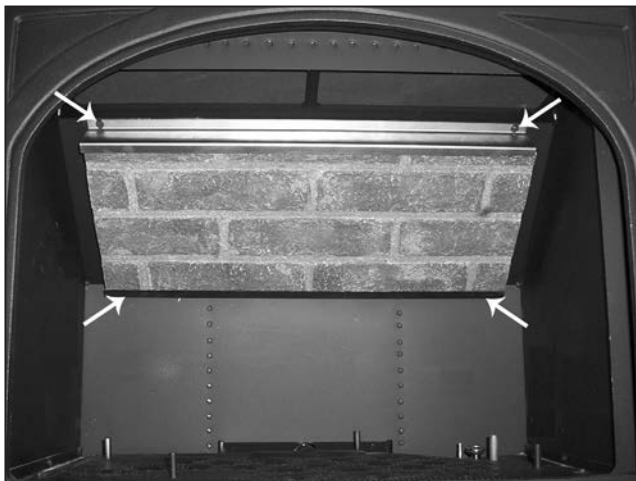

Figure 61: Top brick panel in place, screws shown.



Figure 62: Back brick panel in place.



Figure 63: Side brick panels in place.

2. Remove the two (2) screws from the front of the baffle. Slide the top brick panel into the bottom bracket and place the other brick bracket over the top of the panel and line up the slots on the bracket with the holes at the top of the baffle. Use two (2) of the provided screws to hold the bracket in place. Ensure the top panel is centered before tightening the four (4) screws completely (refer to Figure 61).
3. Slide the bottom brick panel into place under/behind the top panel bracket, the notched side is to rest on the firebox bottom. The panel should rest flush with the back of the firebox (refer to Figure 62).
4. Slide each side brick panel into place along the sides of the firebox. The panels should rest flush with the back panel and the sides of the firebox (refer to Figure 63).

# SECONDARY INSTALLATION

## **INSTALLATION OF SAFETY SCREEN:**

The safety screen supplied with the Wesport simply clips onto the outside cast doors when they are closed. Please note that the safety screen cannot be used when the cast doors are open. To install and remove the safety screen follow the steps below:

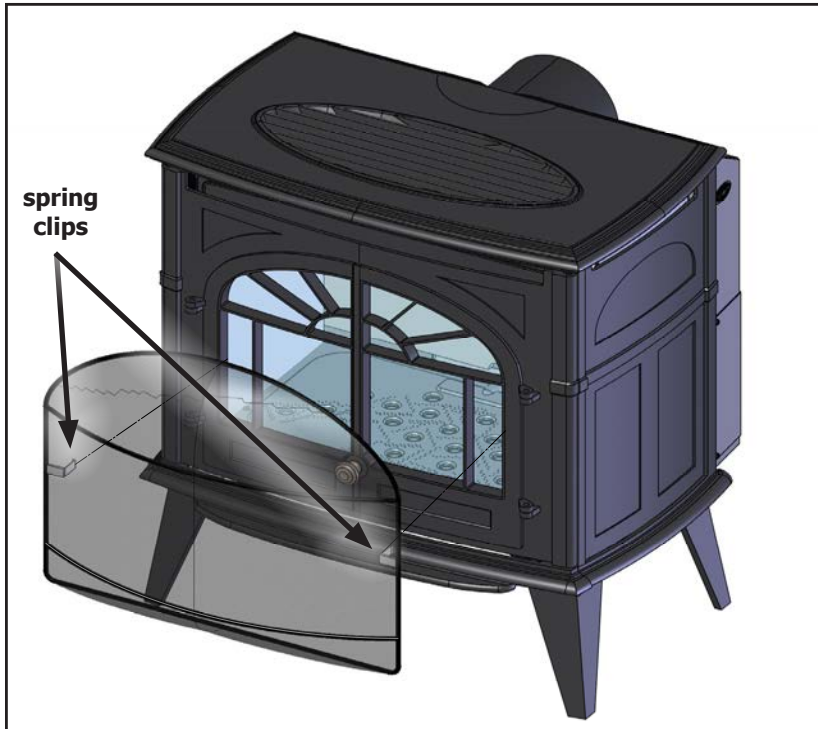

**Figure 64: Safety Screen Installation**

### Safety Screen Installation

1. Align the spring clips on the side of the screen with the inside edge of the cast door (see Figure 64)
2. Push safety screen into place until spring clips latch onto the cast doors.

### Safety Screen Removal

1. If the unit has been running turn it off and allow it to fully cool before attempting to remove the safety screen.
2. Push the sides of the safety screen inwards, towards each other, to release the spring clips and remove the safety screen (see Figure 65).

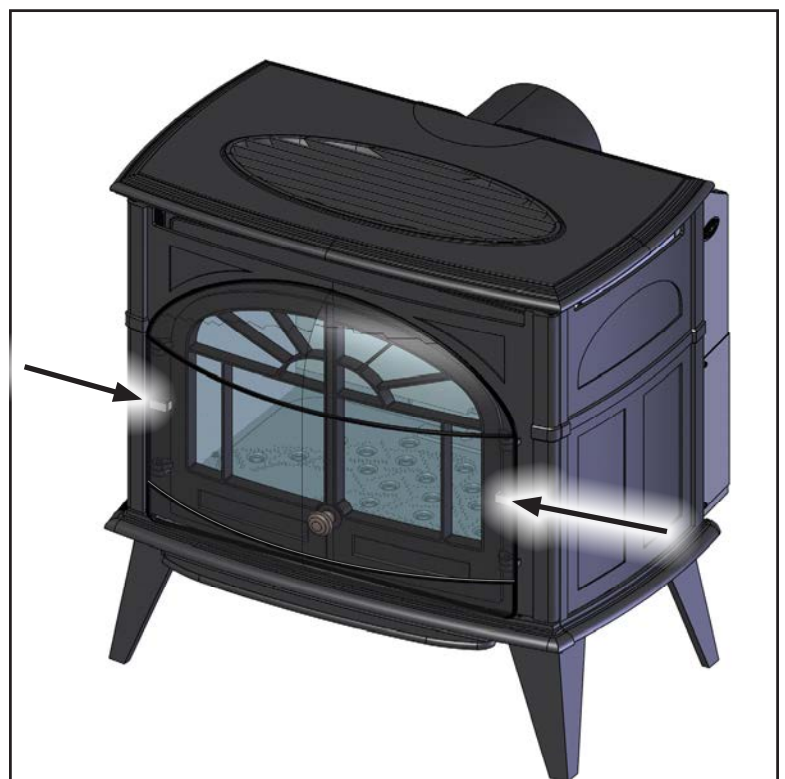

**Figure 65: Safety Screen Removal**

# TROUBLE SHOOTING

Problem	Possible Cause	Solution
The main burner does not ignite when called for.	The gas valve may not be on.	<ul style="list-style-type: none"> <li>• Check that the gas control knob is in the "ON" position.</li> </ul>
	Thermostat is not calling for heat.	<ul style="list-style-type: none"> <li>• Adjust the thermostat several degrees above ambient temperature.</li> </ul>
	Problem with gas valve.	<ul style="list-style-type: none"> <li>• Use a DC voltmeter to measure the voltage across the TPTH and TP terminals. Main operator voltage: Open circuit <math>\geq</math> 325mV Closed circuit <math>\geq</math> 100mV</li> <li>• If voltage is not present, check the control circuit for proper operation.</li> <li>• If proper control system voltage is present, replace the gas control.</li> </ul>
Spark will not light the pilot after repeatedly pressing the spark ignitor.	Defective piezo ignitor.	<ul style="list-style-type: none"> <li>• Check connections to ignitor.</li> <li>• If ignitor connections are good but no spark, replace ignitor.</li> </ul>
	Broken spark electrode.	<ul style="list-style-type: none"> <li>• Check for broken ceramic insulation, replace electrode if broken.</li> </ul>
	Misaligned spark electrode.	<ul style="list-style-type: none"> <li>• If spark is not arcing from electrode to pilot, loosen the screws on the pilot base adjust and tighten.</li> </ul>
Pilot will not remain lit.	Problem with thermocouple circuit.	<ul style="list-style-type: none"> <li>• Check for proper connection of the thermocouple to the rear of the valve. If loose, fully tighten.</li> <li>• Check pilot for full flame impingement around thermocouple. If flame is too small, check gas pressure, adjust pilot rate screw, check pilot head for damage.</li> <li>• Check thermocouple voltage at valve. It must be greater than 5 mV. If low, replace thermocouple.</li> </ul>
	Air in gas line (pilot dies while knob is depressed).	<ul style="list-style-type: none"> <li>• Bleed line.</li> <li>• Check gas line pressure.</li> <li>• Contact dealer.</li> </ul>
Burners will not remain lit.	Problem with thermopile circuit.	<ul style="list-style-type: none"> <li>• Check gas line pressure .</li> <li>• Check for flame impingement on thermopile. If low, see "Pilot will not remain lit".</li> <li>• Check thermopile for minimum of 300 mV when burner is switched on.</li> <li>• Check wiring to thermostat for breaks.</li> </ul>
Flame lifting	Leak in vent pipe	<ul style="list-style-type: none"> <li>• Check for leaks in vent connections.</li> </ul>
	Improper vent configuration	<ul style="list-style-type: none"> <li>• Check vent configuration with manual.</li> </ul>
	Terminal may be recirculating flue gases	<ul style="list-style-type: none"> <li>• Check to see if terminal is on correctly.</li> <li>• May need to install high wind termination cap.</li> <li>• Contact dealer.</li> </ul>
Glass fogs up	Normal Condition: after the appliance warms up the glass will clear. **Due to additives in gas, glass may get hazy during operation** Clean as needed.	
Blue Flames	Normal during start up: flames will yellow as the fireplace heats up.	
Flames are burning "dirty" or sooting	Flame impingement	<ul style="list-style-type: none"> <li>• Check log positioning.</li> <li>• Increase primary air by opening the venturi shutter and/ or by opening the vent restrictor.</li> </ul> See also "Burners will not remain lit."
Remote control doesn't work	Problem with the remote	<ul style="list-style-type: none"> <li>• One or more of the batteries are dead. See remote control instructions.</li> </ul>
	Problem with fireplace	<ul style="list-style-type: none"> <li>• The on/off switch is turned to OFF.</li> <li>• The gas control valve is turned to PILOT or OFF.</li> <li>• The pilot has gone out.</li> </ul>



# PARTS LIST - CAST

Reference Number	Part Description	Part Number
1	Top Vent Insert Piece - Painted	EGWP-503
1	Top Vent Insert Piece - Antique Chestnut	50-870
2	Top Grate - Painted	EGWP-502
2	Top Grate - Antique Chestnut	50-869
3	Top Only (No Grate Or Vent Insert) - Painted	50-368
3	Top Only (No Grate Or Vent Insert) - Antique Chestnut	50-906
4	Side Panel (Left) - Painted	EGWP-504
4	Side Panel (Left) - Antique Chestnut	50-871
5	Side Panel (Right) - Painted	EGWP-505
5	Side Panel (Right) - Antique Chestnut	50-872
6	Cast Leg (Each) - Painted	EGWP-508
6	Cast Leg (Each) - Antique Chestnut	50-875
7	Ash Shelf - Painted	EGWP-507
7	Ash Shelf - Antique Chestnut	50-874
8	Cast Front Complete (Doors & Ash Shelf) - Painted	EGWP-506
8	Cast Front Complete (Doors & Ash Shelf) - Antique Chestnut	50-873
	Top Complete (Top, Vent Insert, & Grate) - Painted	EGWP-501
	Top Complete (Top, Vent Insert, & Grate) - Antique Chestnut	50-868
	Complete Cast Body - Painted	50-562
	Complete Cast Body - Antique Chestnut	50-876

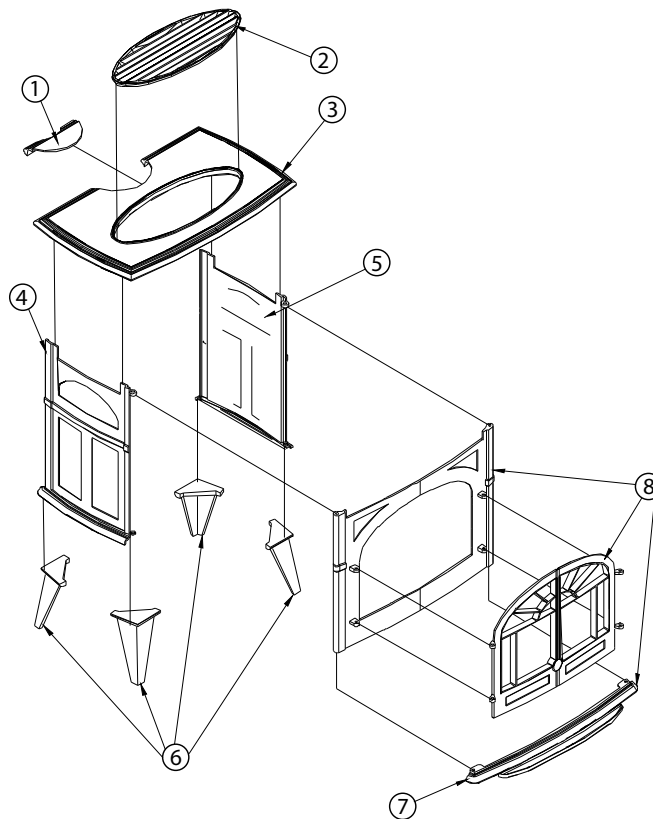

## PARTS LIST - COMPONENTS

Reference Number	Part Description	Part Number
9	120° Ceramic Fan Temperature Sensor	EC-001
10	S.I.T. Nova Valve Convertible	50-1421
11	Thermocouple	EC-009
11	Spark Electrode with Ignitor Cable	EC-011
11	Thermopile	EC-012
11	Pilot Orifice NG Threaded	EC-019
11	Pilot Orifice LP Threaded	EC-020
	Pilot Gasket	EC-021
	S.I.T. Piezo Ignitor	EC-023
12	Burner Switch	EC-026
13	Fan Controller 115 V With Knob	EC-039A
13	Fan Controller Knob	EC-040
	Domestic Power Cord	EC-042
	HEYCO Strain Relief	EC-044
	DV Vent Kit With Coupler	EC-061
14	Relief Door Gasket Only	50-3369
14	Window Channel Tape	50-634
14	1 Piece Glass With Tape	EGWP-090
14	Inner Door Only - Painted	EGWP-092
	Burner Control Assembly LP	EGWP-099
	Burner Control Assembly NG	EGWP-100
	Door Hinge Pin - Silver	EGWP-510
	Westport Fireplace Screen	50-3077
	Shoulder Bolt, Hardened Bushing & Nut (Set of 2)	EF-124
	Levelling Bolts	30-013
	Door Knob Clip	30-029
	Door Latch Assembly - Nickel	30-033
15	Valve Mounting Bracket	30-047
16	Rear Shield	30-048
17	Rating Plate (Label)	30-049
18	Gas Valve Cover	30-050
	Flue Connection	30-051
19	Inner Door Handles (2 per set)	50-457
20	Venturi Adjustment Rod	30-053
21	Firebox	30-054
22	Pan Burner Only	30-055
23	45° Elbow & Gasket	50-040

## PARTS LIST - COMPONENTS

Reference Number	Part Description	Part Number
24	Fan Kit 180 C.F.M.	50-3621
	Door Knob - Brushed Nickel	50-262
	Electronic Ignition Module Switch	50-329
25	Blank Orifice #73 - All Gas Models	50-343
	Wiring Harness	50-348
	Pressure Relief Door With Gasket	50-3369
	Control Panel Decal	50-461
	Inner Door Complete (With Glass & Handles)	50-463
	Embers	50-491
	4" Flex Coupler	50-497
26	Dual Convection Blower 115 V (No Mount)	50-512
	Firebox Baffle	50-533
	Valve Extension Rod With Knob (1 per set)	50-555
27	Electronic Ignition Module	50-589
28	Control Panel	50-690
	Drafhod Adapter	50-841
	Drafhod Adaptor Spill Switch Assembly (with Wiring Harness)	50-885
29	3 Flame Pilot Hood	50-925
	Owner's Manual	50-1033
	Brick Panel Set	50-1038
	Log Set With Embers - Complete	50-1041
	Conversion Kit from LG to NG Convertible	50-1442
	Conversion Kit from NG to LG Convertible	50-1443
	S.I.T. Valve Conversion Screw With O-Ring	50-1450
	S.I.T. Valve Conversion Screw Cap	50-1451

# PARTS DIAGRAM - COMPONENTS

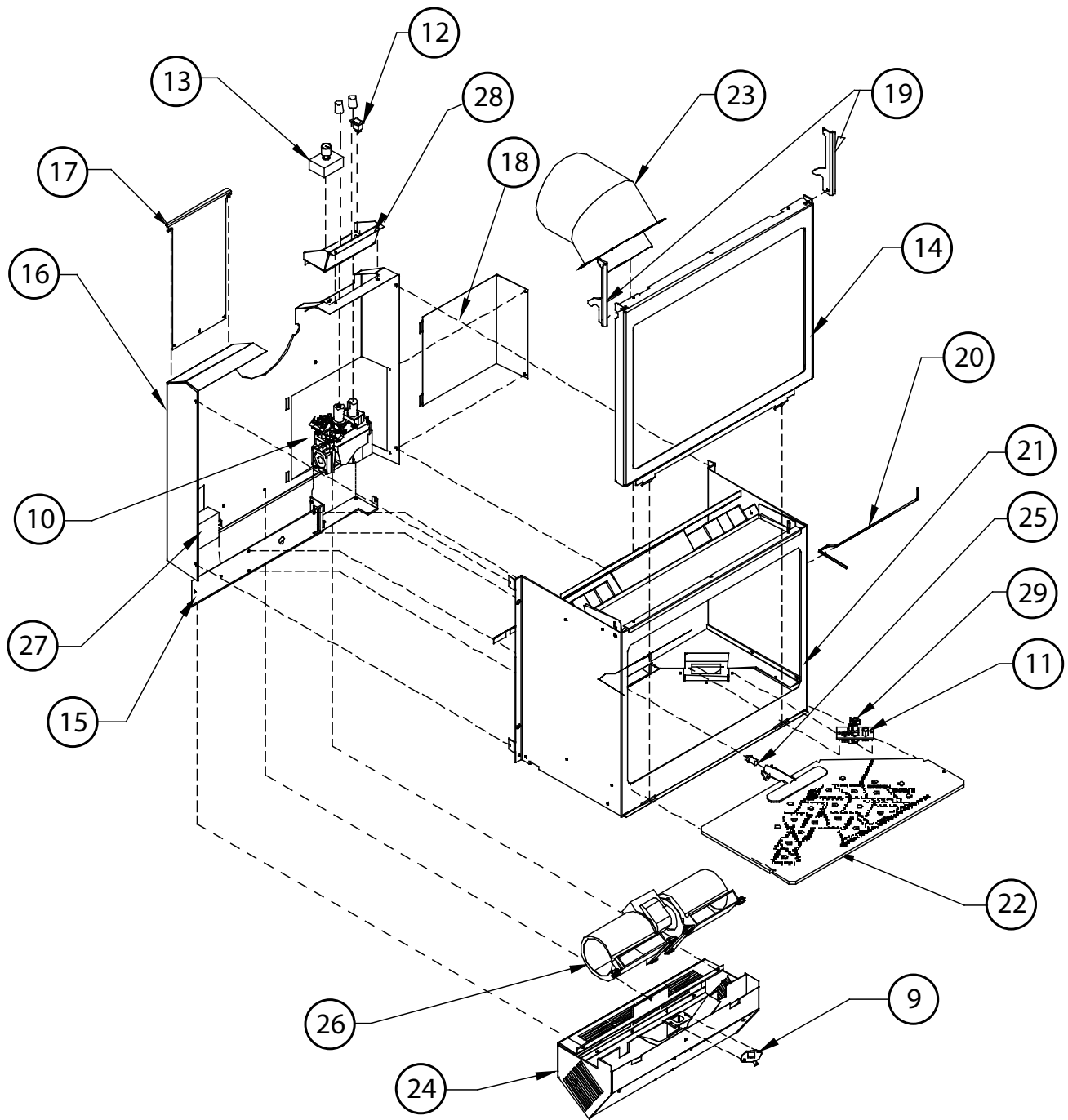



# Warranty for Enviro Gas Products

Sherwood Industries Ltd. ("Sherwood") hereby warrants, subject to the terms and conditions herein set forth, this product against defects in material and workmanship during the specified warranty period starting from the date of original purchase at retail. In the event of a defect of material or workmanship during the specified warranty period, Sherwood reserves the right to make repairs or to assess the replacement of a defective product at Sherwood's factory. The shipping costs are to be paid by the consumer. All warranties by Sherwood are set forth herein and no claim shall be made against Sherwood on any oral warranty or representation.

## Conditions

- A completed warranty registration must be submitted to Sherwood within 90 days of original purchase via the online warranty registration page or via the mail-in warranty registration card provided. Have the installer fill in the installation data sheet in the back of the manual for warranty and future reference.
- This warranty applies only to the original owner in the original location from date of install.
- The unit must have been properly installed by a qualified technician or installer, and must meet all local and national building code requirements.
- The warranty does not cover removal and re-installation costs.
- Sherwood Industries Ltd. reserves the right to make changes without notice.
- Sherwood Industries Ltd. and its employees or representatives will not assume any damages, either directly or indirectly caused by improper usage, operation, installation, servicing or maintenance of this appliance.
- A proof of original purchase must be provided by you or the dealer including serial number.
- This warranty does not cover any discoloration of the safety screen mesh.

## Exclusions

An expanded list of exclusions is available at [www.enviro.com/help/warranty.html](http://www.enviro.com/help/warranty.html)

This warranty does not cover:

- Damage as a result of improper usage or abuse.
- Damage caused from over-firing due to incorrect setup or tampering.
- Damage caused by incorrect installation.

## To the Dealer

- Provide name, address and telephone number of purchaser and date of purchase.
- Provide date of purchase. Name of installer and dealer. Serial number of the appliance. Nature of complaint, defects or malfunction, description and part # of any parts replaced.
- Pictures or return of damaged or defective product may be required.

## To the Distributor

- Sign and verify that work and information are correct.

### Sherwood Industries Ltd.

6782 Oldfield Road, Victoria, BC . Canada V8M 2A3  
 Online warranty registration: [www.enviro.com/warranty/](http://www.enviro.com/warranty/)

Category	One Year	Two Year	Limited Lifetime (7yr)
Parts <sup>1,2</sup> (unit serial number required)		✓	
Firebox Liner Panels <sup>3</sup>		✓	
Firebox			✓
Heat Exchanger			✓
Burner			✓
Ceramic Logs <sup>4</sup>			✓
Ceramic Glass <sup>5</sup>	✓		
Pedestal / Legs (excluding finish)			✓
Door Assembly			✓
Surround Panels (excluding finish)			✓
Exterior Panels (excluding finish)			Up to 5 years
Electrical Components		✓	
Exterior Surface Finishing	✓		
Labour	✓		

<sup>1</sup> Whereas warranty has expired, replacement parts will be warrantied for 90 days from part purchase date. Labour not included. Unit serial number required.

<sup>2</sup> 50-173 Westport Fan Kit covered for up to 5 years from purchase date. Labour not included. Unit serial required.

<sup>3</sup> Excluding damage to the finish caused by improper setup of the appliance, or color changes.

<sup>4</sup> Log set and panels excludes wear and tear or breakage caused by cleaning or service.

<sup>4</sup> Glass is covered for thermal breakage. Photos of box, inside of door, and unit serial # must be supplied for breakage due to shipping.

<sup>6</sup> Exterior Surface finishing covers plating, enamel or paint and excludes colour changes, chipping, and fingerprints. Travel costs not included.

# INSTALLATION DATA SHEET

The following information must be recorded by the installer for warranty purposes and future reference.

NAME OF OWNER:  
\_\_\_\_\_  
  
ADDRESS:  
\_\_\_\_\_  
\_\_\_\_\_  
\_\_\_\_\_  
  
PHONE: \_\_\_\_\_

NAME OF DEALER:  
\_\_\_\_\_  
  
ADDRESS:  
\_\_\_\_\_  
\_\_\_\_\_  
\_\_\_\_\_  
  
PHONE: \_\_\_\_\_

MODEL: \_\_\_\_\_  
SERIAL NUMBER: \_\_\_\_\_  
DATE OF PURCHASE: \_\_\_\_\_ (dd/mm/yyyy)  
DATE OF INSTALLATION: \_\_\_\_\_ (dd/mm/yyyy)  
  
 NATURAL GAS (NAT)       PROPANE (LPG)  
  
INLET GAS PRESSURE: \_\_\_\_\_ in wc  
MAIN BURNER ORIFICE: \_\_\_\_\_ # DMS  
PILOT ORIFICE # \_\_\_\_\_ OR \_\_\_\_\_ in diam.  
INSTALLER'S SIGNATURE:  
\_\_\_\_\_

NAME OF INSTALLER:  
\_\_\_\_\_  
  
ADDRESS:  
\_\_\_\_\_  
\_\_\_\_\_  
\_\_\_\_\_  
  
PHONE: \_\_\_\_\_

MANUFACTURED BY:  
SHERWOOD INDUSTRIES LTD.  
6782 OLDFIELD RD. SAANICHTON, BC, CANADA V8M 2A3  
www.enviro.com  
October 2022  
C-14514