

# ENERVEX ADC150 DRAFT CONTROL

3916068 05.17

Installation & Operating Manual

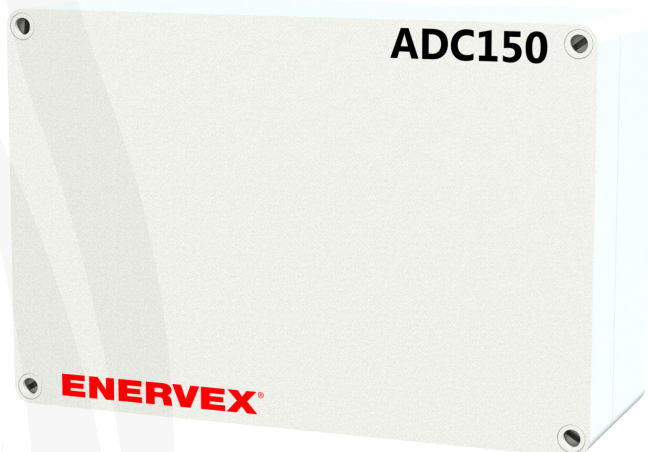

**READ AND SAVE THESE INSTRUCTIONS!**



**Intertek**

ENERVEX Inc.  
1685 Bluegrass Lakes  
Parkway  
Alpharetta, GA 30004  
USA

P: 770.587.3238  
F: 770.587.4731  
T: 800.255.2923  
info@enervex.com  
www.enervex.com

**ENERVEX®**   
VENTING DESIGN SOLUTIONS



The ADC150 Fan Control is ETL Listed in the U.S. and Canada: under UL 508 Standard for Industrial Control Equipment (17th Ed.) and CSA C22.2 No. 14-05- Standard for Industrial Control Equipment.

**IMPORTANT: READ THESE INSTRUCTIONS CAREFULLY PRIOR TO INSTALLATION.**

- **EXAMINE ALL COMPONENTS FOR POSSIBLE SHIPPING DAMAGE PRIOR TO INSTALLATION.**
- **DIFFERENT MANUFACTURERS HAVE DIFFERENT JOINT SYSTEMS AND ADHESIVES. DO NOT MIX PIPE, FITTINGS, OR JOINING METHODS FROM DIFFERENT MANUFACTURERS.**

**Symbol Legend**

The following terms are used throughout this manual to bring attention to the presence of potential hazards, or to important information concerning the product.



**DANGER:** Indicates an imminent hazardous situation which, if not avoided, will result in death, serious injury or substantial property damage.



**WARNING:** Indicates an imminent hazardous situation which, if not avoided, may result in personal injury or property damage.

**How to use this manual**

This installation manual does not contain any system design documentation. System design documentation is available from any authorized ENERVEX representative. Accessories, fans, and variable frequency drives are not covered by this manual. Please refer to these component's individual manuals.

**TO REDUCE THE RISK OF FIRE, ELECTRICAL SHOCK OR INJURY TO PERSONS, OBSERVE THE FOLLOWING:**

1. Use this unit in the manner intended by the manufacturer. If you have questions, contact the manufacturer at the address or telephone number listed on the front of the manual.
2. Before servicing or cleaning the unit, switch off at service panel and lock service panel to prevent power from being switched on accidentally.
3. Installation work and electrical wiring must be done by a qualified person(s) in accordance with applicable codes and standards.
4. Follow the appliance manufacturer's guidelines and safety standards such as those published by the National Fire Protection Association (NFPA), and the American Society for Heating, Refrigeration and Air Conditioning Engineers (ASHRAE), and the local code authorities.
5. This unit must be grounded.

## Content

### 1. PRODUCT INFORMATION

1.1 Function.....	4
1.2 Shipping .....	4
1.3 Warranty .....	4

### 2. SPECIFICATIONS AND DIMENSIONS

2.1 Dimensions and Capacities.....	5
------------------------------------	---

### 3. MECHANICAL INSTALLATION

3.1 Location.....	6
3.2 Mounting the Control Unit .....	6
3.3 Mounting the Pressure Transducer.....	7
3.4 Installation of the Stack Probe.....	7
3.5 Connecting the XTP and the Stack Probe .....	8

### 4. ELECTRICAL INSTALLATION

4.1 General.....	9
4.2 Connection Diagram .....	10
4.3 Wiring a Gas Fireplace .....	11
4.4 Wiring a Gas Fireplace with a MFD .....	12
4.5 Wiring a 3-Phase Fan.....	13
4.6 Integrated with External PDS .....	14

### 5. STARTUP AND CONFIGURATION

5.1 General.....	15
5.2 Setting Operation Pressure .....	19
5.3 Setting Alarm Time .....	21

### 6. MAINTENANCE AND TROUBLESHOOTING

---

## 1. PRODUCT INFORMATION

### 1.1 FUNCTION

The ENERVEX ADC150 is an Automated Draft Control used to monitor and maintain constant

draft for gas fired appliances such as a fireplace or furnace.

This is achieved by modulating the speed of a fan or ventilator directly or indirectly via a Variable Frequency Drive (VFD). The ADC150 is for use with ENERVEX model RS or GSV fans and is a component in the residential IntelliDraft System.

The control monitors pressure in a chimney system via a pressure transducer (XTP) and maintains the desired draft by modulating the fan speed.

The ADC150 has an integrated safety system that assures the appliance(s) shuts down in the event of an electrical or mechanical failure in the system. The control can be interlocked with up to two appliances. Connections are made at the Aux In and Aux Out terminals and when the appliance(s) is activated, the control will start the fan and once the specified pressure is achieved, the control regulates the voltage output to maintain the specified pressure in the chimney. In the event of insufficient draft, the control assures the appliance(s) shuts down after 15s (default setting is 15s but it can be adjusted up to 180s, refer to local codes for maximum allowable time). It also features a post purge function that keeps the fan running for 3 minutes after the last appliance shuts down to evacuate any remaining flue gases in the chimney.

The ADC150 can be interlocked to a MFD (Mechanical Fireplace Damper) which ensures that the damper is open before releasing the appliance for operation. If at any point the control has sensed the damper has failed and is no longer in the open position, it will go into alarm for 30 seconds and will attempt to reinitialize.

The housing is NEMA 1 rated ABS plastic.

System installation must conform to the requirements of the authority having jurisdiction. When required by the authority having jurisdiction, the installation must also conform to the NFPA31, NFPA54 or NFPA211.

All electrical wiring must be in accordance with the requirements of the authority having jurisdiction or, in absence of such requirements, with the National Electric Code, NFPA 70.

### 1.2 SHIPPING

ADC150 contains the following: the ADC150 control unit, pressure transducer (XTP), duct probe and silicone tubing.

\* If other components are shipped, they will appear as separate items on the packing list.

### 1.3 WARRANTY

2-Year Factory Warranty. Complete warranty conditions are available from ENERVEX, Inc.

## 2. SPECIFICATIONS

### 2.1 DIMENSIONS AND CAPACITIES

ADC150		
Power Supply	V	1x120VAC
Amperage	A	7.0
Operating Temperature	°F/°C	-4 to 122/-20 to 50
Range of Operation	inWC/Pa	0.05-0.55/12.5-137.5
Tolerance	inWC/Pa	0.01/3 +/-10%
Control Signal	mA	Max. 10
Control Relay		Max. 120 VAC/8A
Output	VAC	10-120
	VDC	0-10
Dimensions	A in/mm	9.6 / 244
	B in/mm	6.3 / 160
	C in/mm	3.5 / 90
Weight	lbs/kg	2.6 / 1.2
EMC Standard	Emission	EN 50 081-1
	Immunity	EN 50 082-2
XTP Sensor		
Power Supply	VDC	12-36
Amperage	mA	<20
Output	VDC	0-10
Operating Temperature	°F/°C	0 to 160 / -18 to 71
Accuracy	inWC/Pa	+/-0.08%
Dimensions	D in/mm	3.70 / 94
	E in/mm	5.12 / 130
	F in/mm	6.18 / 157
	G in/mm	3.13 / 80
Weight	lbs/kg	.6 / .3
Stack Probe		
Dimensions	H in/mm	4.25/108
	I in/mm	3.50/89

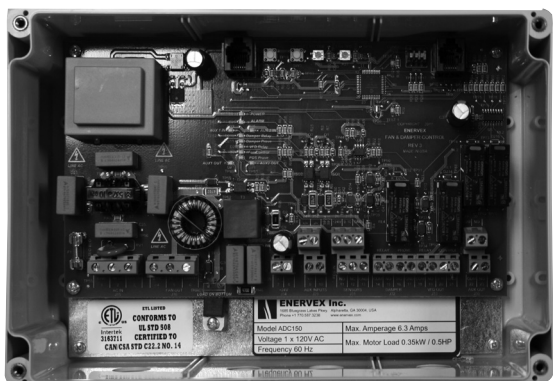
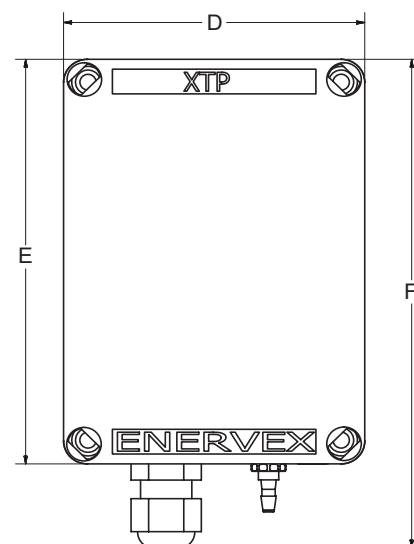
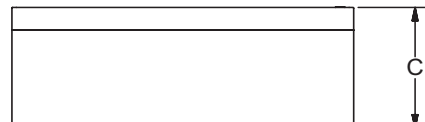
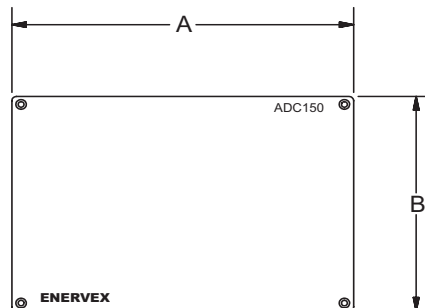

ADC150

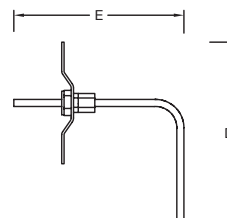
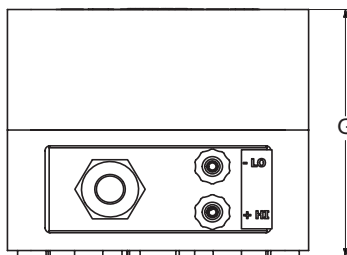

### 3. MECHANICAL INSTALLATION

#### 3.1 LOCATION

The ADC150 Control Unit must be installed indoors. As shown in Fig. 1, the control will be wired directly to a 120/1/60 VAC power supply. The control will also be connected to the fan, appliance and damper (if used). For detailed wiring information, see Chapter 4.

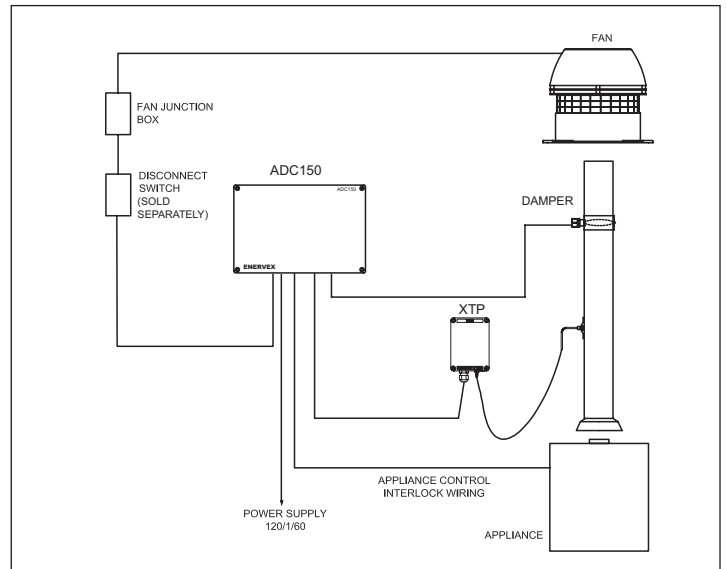

Fig. 1

#### 3.2 MOUNTING THE CONTROL UNIT

The ADC150 control may be mounted directly to a wall or similar. To mount, remove the cover and locate the (4) mounting holes as shown in Figure 2.

When locating the ADC 150 control, make sure that the distance between the control and the pressure transducer does not exceed three hundred (300) feet.

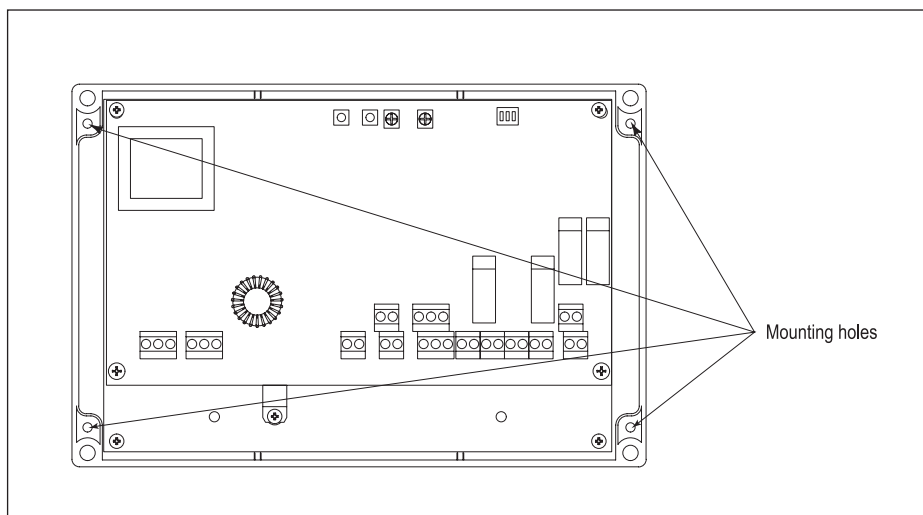

Fig. 2

### 3.3 MOUNTING THE PRESSURE TRANSDUCER

The transducer can be mounted in any orientation and should be mounted within six (6) feet of the duct probe (see Figure 3). The mounting holes for the transducer are shown in Figure 4.

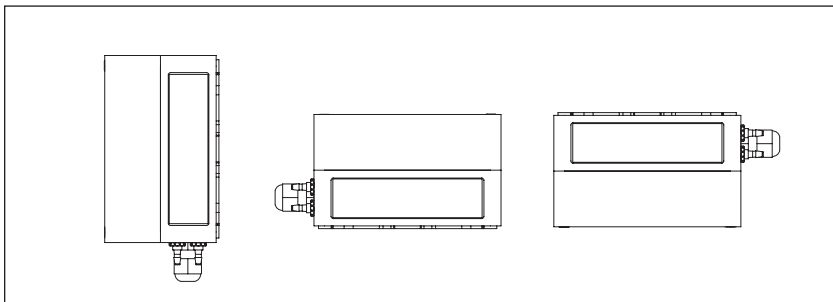

Fig. 3

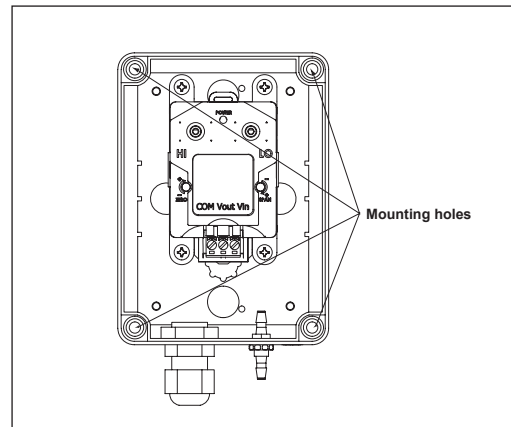

Fig. 4

### 3.4 INSTALLATION OF THE STACK PROBE

The probe must be installed between the appliance and the exhaust fan at a point where the draft needs to be maintained. This could be near the appliance outlet. If a damper is used in the system, the stack probe should be installed between the appliance and the damper.

Locate the probe at least three (3) vent diameters away from any elbow, tee or damper to ensure stable readings.

(Figure 5)

To provide an accurate pressure reading, the probe should be installed with the tip of the tube protruding no more than 1/8" inside the inner wall of the chimney or stack. (Figure 6)

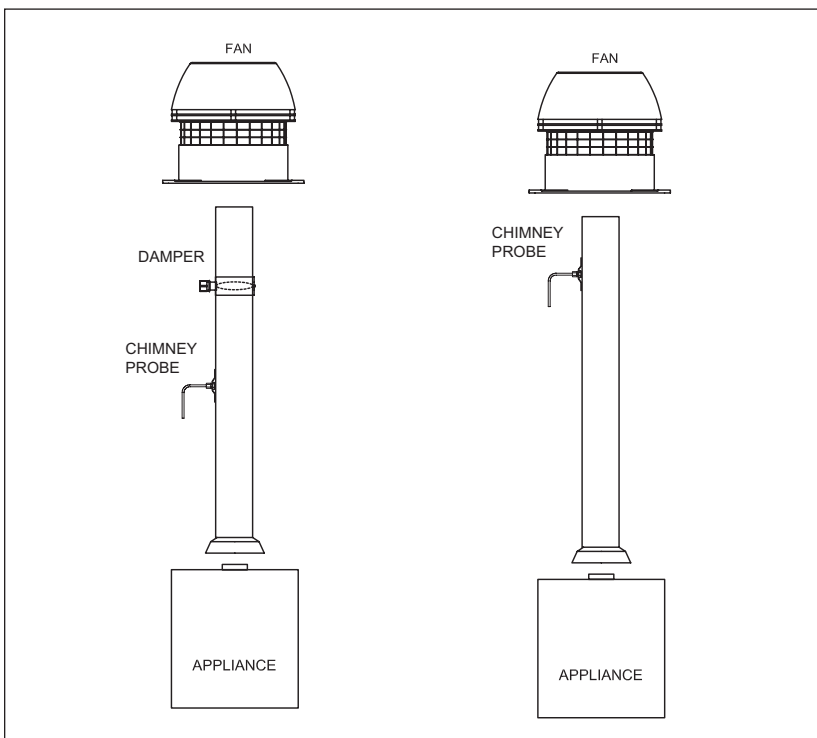

Fig. 5

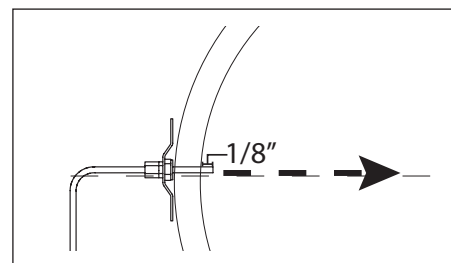

Fig. 6

### 3.5 CONNECTING TRANSDUCER TO STACK PROBE

The transducer (XTP) is connected to the duct probe via silicone tubing. Connect one end of the silicone tubing to the duct probe and the other end to the NEGATIVE (-) port of the transducer as shown in Figure 7.

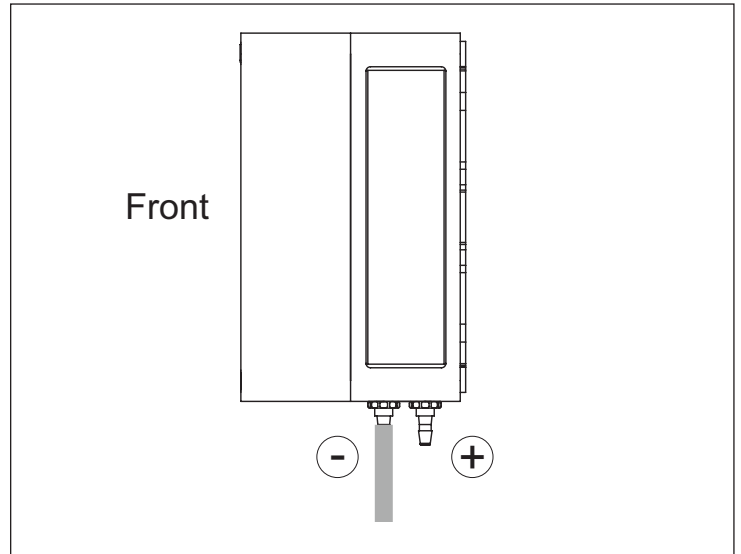

Fig. 7



## 4. ELECTRICAL INSTALLATION

### 4.1 GENERAL



#### DANGER

Turn off electrical power before servicing. Contact with live electric components can cause shock or death.



ADC150 is designed for 1x120VAC power supply only. Fan output is regulated on the neutral side and cannot be shared with other circuits.

The designations for each terminal on the control board are shown below. Note that some installations may not require the use of all terminals. Also shown in this section is a general connection diagram for an ADC100 control system.

The terminals are connected as shown on Figure 8:

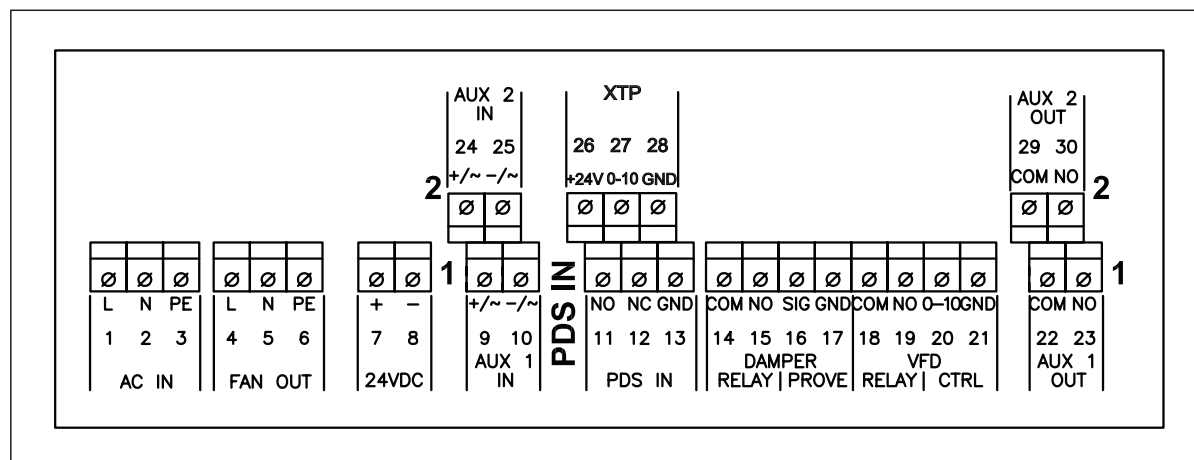

Fig. 8

Terminal	Use	Terminal	Use
1	Power Supply - L1	14-15	Damper Relay
2	Power Supply - N	16-17	Damper Prove
3	Power Supply - Ground	18-19	VFD Relay
4	Chimney Fan- L1	20	0-10 VDC Output
5	Chimney/Exhaust Fan - N (regulating)	21	0 VDC Output (Gnd)
6	Chimney/Exhaust Fan- Ground	22-23	Auxiliary Appliance Output 1 (Max Amperage 250 VAC 8 A)
7	+ 24 VDC Out	24-25	Auxiliary Appliance Input 2 (10-240 VAC or 5-30 VDC)
8	Ground (-24 VDC) Out	26	XTP- +24 VDC Out
9-10	Auxiliary Appliance Input 1 (10-240 VAC or 5-30 VDC)	27	XTP In (0-10 VDC)
11	PDS- Normally Open	28	XTP In (0 VDC)
12	PDS- Normally Closed	29-30	Auxiliary Appliance Output 2 (Max Amperage 250 VAC 8 A)
13	PDS- Common		

### 4.2 CONNECTION DIAGRAM

The connection diagram shown in Figure 9 below shows typical connections for a single phase fan. If a 3-phase fan is used, a VFD must be connected between the fan and control.

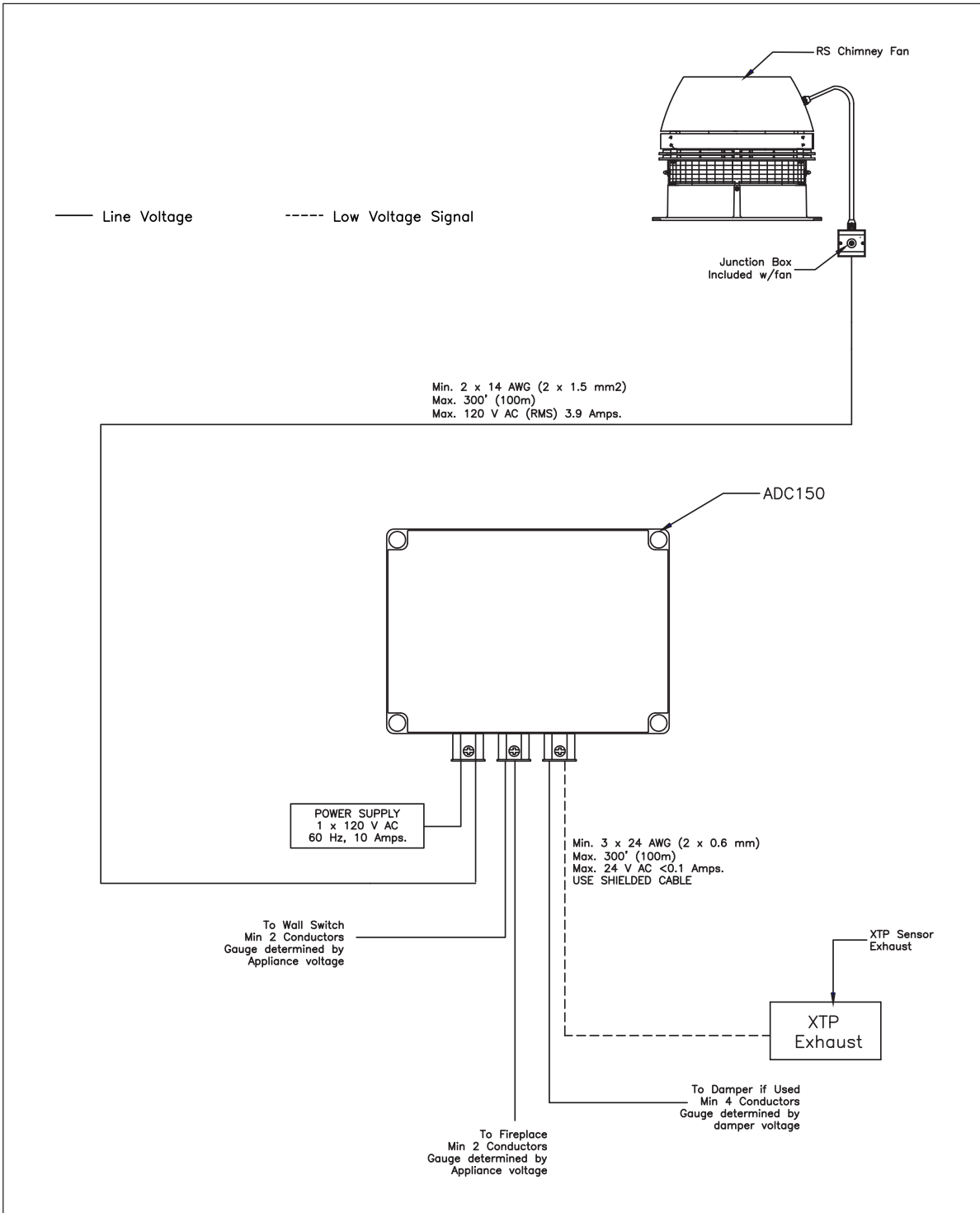

Fig. 9

### 4.3 WIRING OF A GAS FIREPLACE

To interlock the ADC150 with a gas fireplace as shown in Figure 10, connect the Aux In terminals 9 and 10 on the control board to a wall switch. Either by using line voltage or use board voltage from terminals 7 and 8 as depicted below. Connect the gas valve or electronic ignition to Aux Out terminals 22 and 23. Aux Out is a normally open dry contact that closes when the draft set point is met and releases the fireplace for operation. Place a jumper between terminals 16 and 17 if a Mechanical Fireplace Damper (MFD) is not used.

NOTE: See Figure 12 in Section 4.5 for connection of a 3-phase fan with a Variable Frequency Drive.

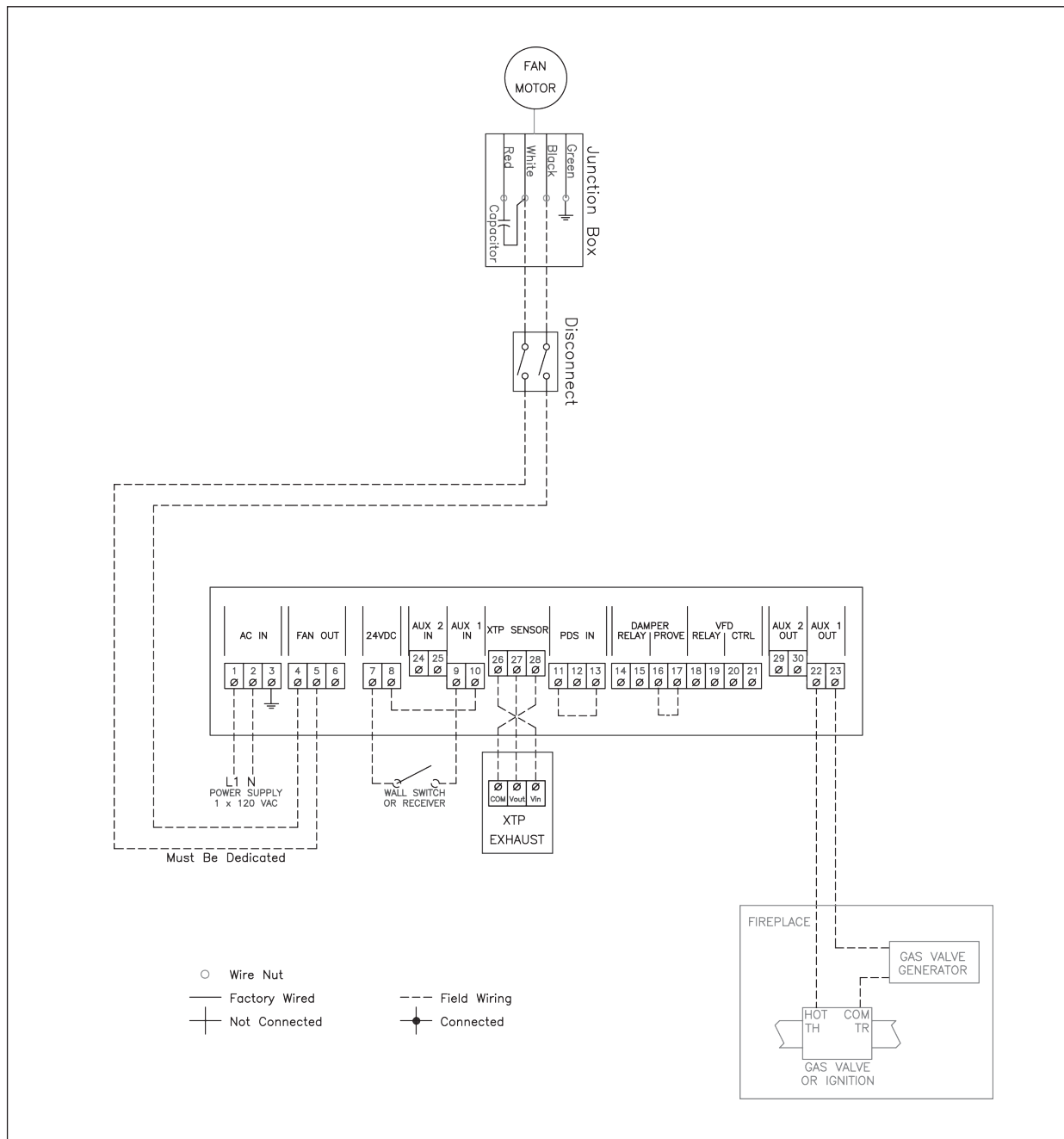

Fig. 10

### 4.4 WIRING OF A GAS FIREPLACE WITH A MFD

To interlock the ADC150 with a gas fireplace and a MFD as shown in Figure 11, follow the procedure outlined in Section 4.3 Wiring of a Gas Fireplace. In lieu of a jumper between terminals 16 and 17, wire in the damper to the control.

NOTE: If an electronic ignition control is used with the fireplace, do NOT interlock it with the damper actuator. The Damper actuator should be interlocked with the ADC150 control only.

To interlock the damper to the control, connect the actuator to terminals 14 and 15 as shown in Figure 11. Damper Relay terminals 14 and 15 is a normally open set of dry contacts

that closes when there is a start signal created by the wall switch. This contact closure is used to send the appropriate power (120VAC or 24VAC) to the actuator to open it. The actuator has an endswitch to enable the damper prove function the ADC150 control requires for operation. Connect the C and NO terminals of the actuator endswitch (damper should be set up to close the C and NO terminals when the damper is open) to terminals 16 and 17 on the control.

NOTE: See Figure 12 in Section 4.5 for connection of a 3-phase fan with VFD.

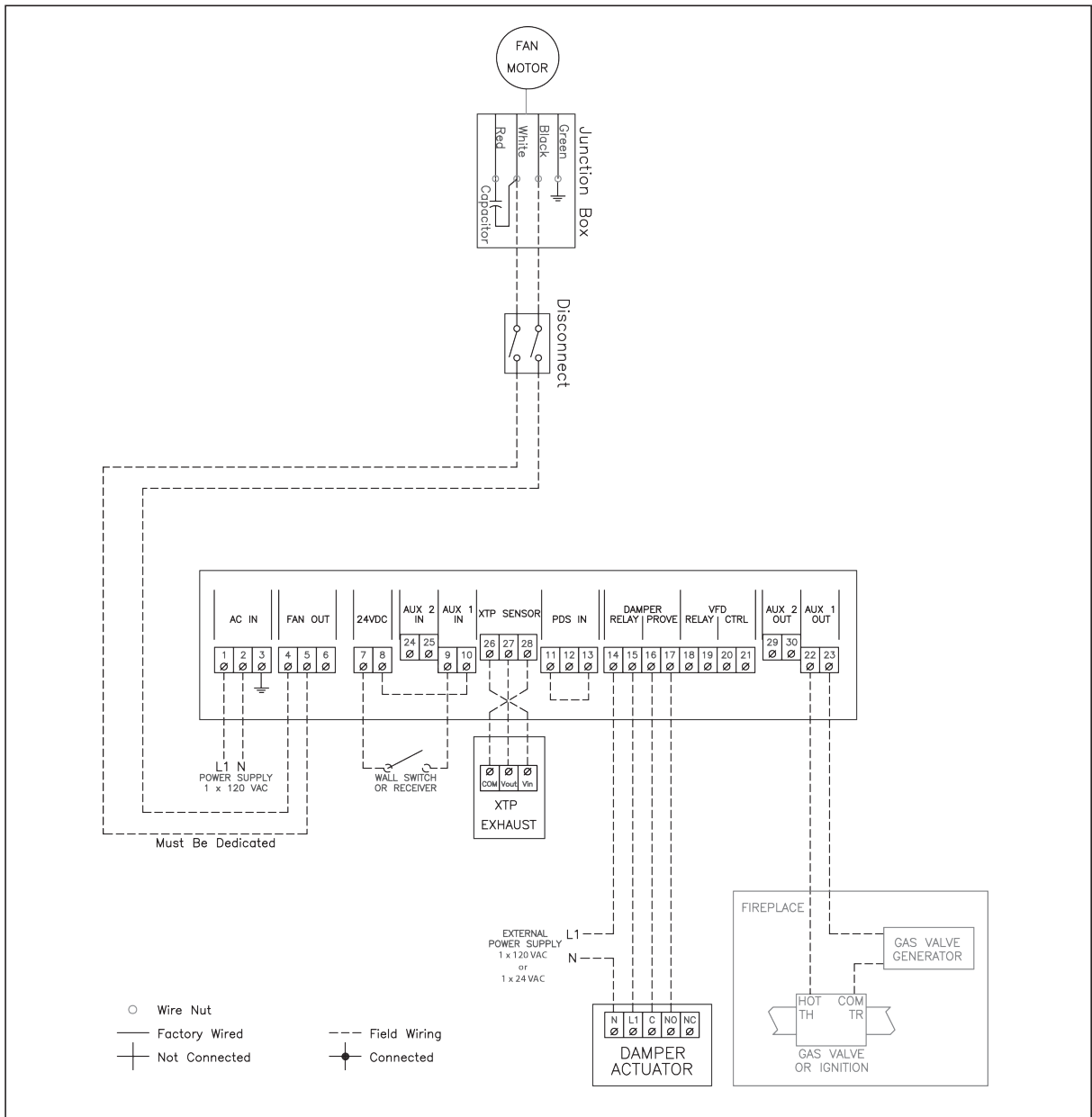

Fig. 11

### 4.5 WIRING OF A 3-PHASE FAN

If a 3-phase fan is used, connect it to the ADC150 control and VFD (sold separately) as shown below. Do NOT connect the fan directly to the control.

The ADC150 sends a 0-10VDC control signal to the VFD which in turn translates the signal to a 0-60 Hz signal to modulate the fan speed. The VFD receives external 3-phase power (200-240 or 380-480 VAC) for operation.

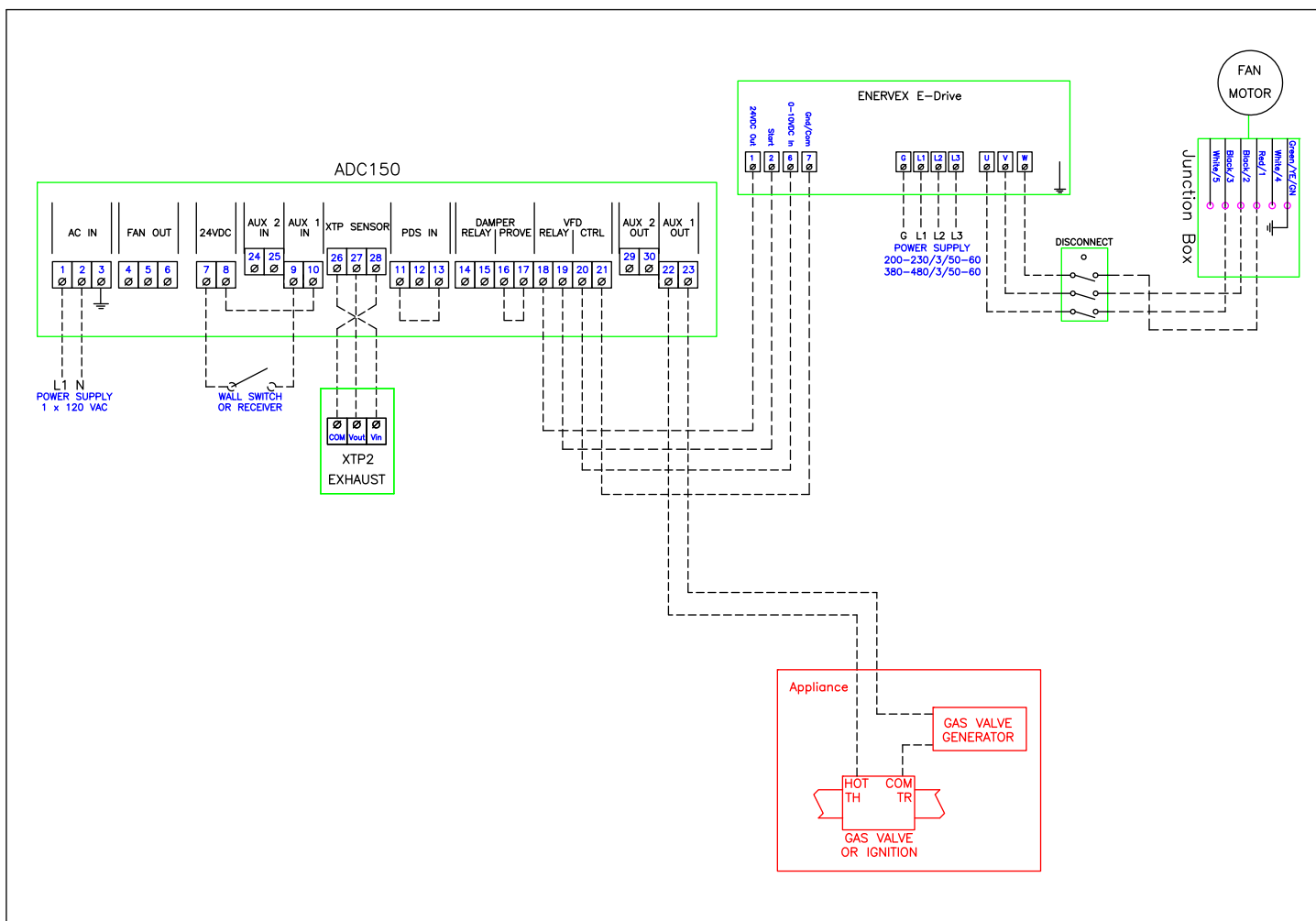

Fig. 12

### 4.6 INTEGRATED WITH EXTERNAL PDS

Figure 13 shows how to connect an external Proven Draft Switch (PDS) to the ADC150. The external PDS is a backup to the XTP and both must be satisfied by sufficient pressure to release the appliance:

- Remove the jumper over terminals 11 and 13 and flip dipswitch 3 to the ON position.
- Connect the PDS to terminals 11, 12, and 13 as shown below.

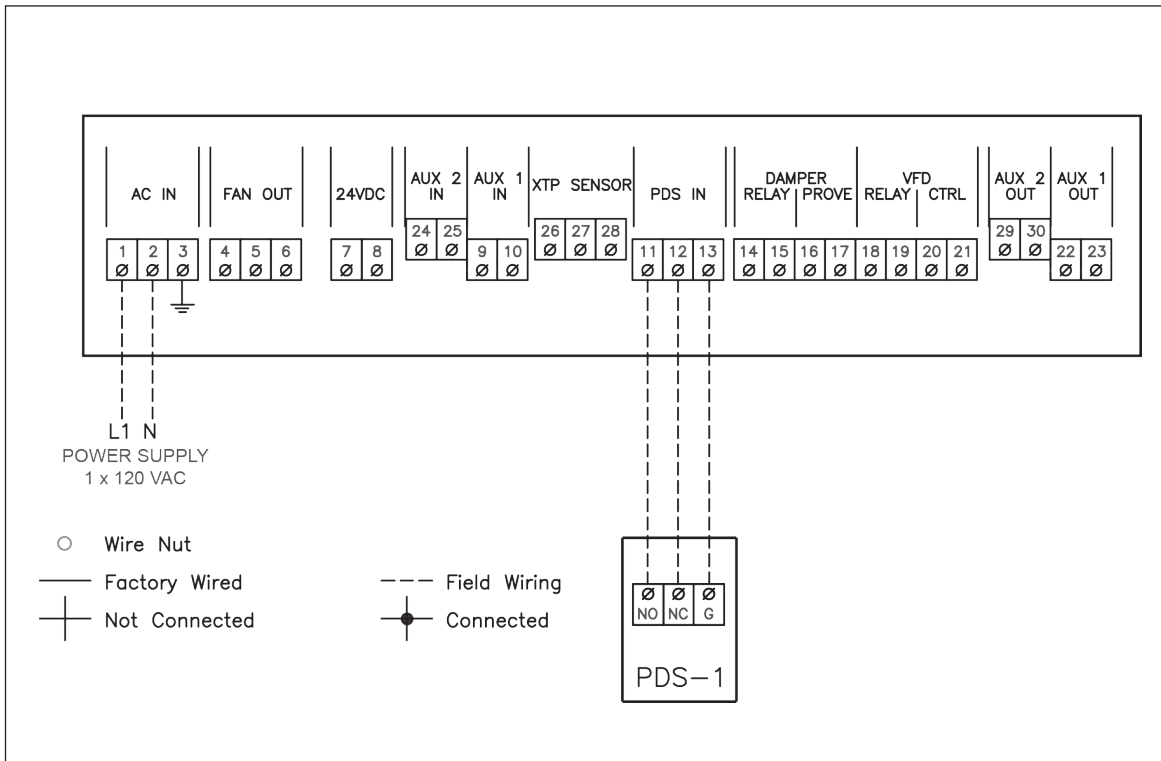

Fig. 13

## 5. STARTUP AND CONFIGURATION

### 5.1 GENERAL

No.	Component	Function
1	Manual Reset Button	Used to reset the control from an alarm condition. Only used when manual reset dipswitch is set to on.
2	Alarm Time Potentiometer	Used to adjust the controls alarm delay time. User adjustable from 15 to 180 seconds. Refer to section 5.3
3	Draft Set Point Potentiometer	Used to adjust the controls draft set point. User adjustable from 0.05" to 0.59" W.C. of draft. Refer to section 5.2
4	Dip Switch Block	Used to adjust functionality of the control: manual reset (1), post purge (2), pds check (3)
5	Power LED	When lit, 120v ac is supplied to the control.
6	Alarm LED	When blinking, an alarm condition has occurred. Refer to section 6 for troubleshooting.
7	AUX 1 in LED	When lit, a call for heat is supplied to the control. Refer to section 4.1 for details.
8	AUX 2 in LED	When lit, a call for heat is supplied to the control. Refer to section 4.1 for details.

No.	Component	Function
9	Damper Relay LED	When lit, the control has closed the relay to open the damper (if used.)
10	Damper Prove LED	When lit, the control has received a contact closure that acts as proof of damper open position (if used.)
11	VFD Relay LED	When lit, the control has closed the relay to start the variable frequency drive (if used.)
12	Fan Control LED	When lit, the control is actively outputting ac voltage to the fan.
13	PDS Prove LED	When lit, the control has received a contact closure that acts as proof of pds closure (if used.)
14	AUX 1 Out LED	When lit, the control has closed the relay for the appliance safety/ start circuit. Refer to section 4.1 for details.
15	AUX 2 Out LED	When lit, the control has closed the relay for the appliance safety/ start circuit. Refer to section 4.1 for details.

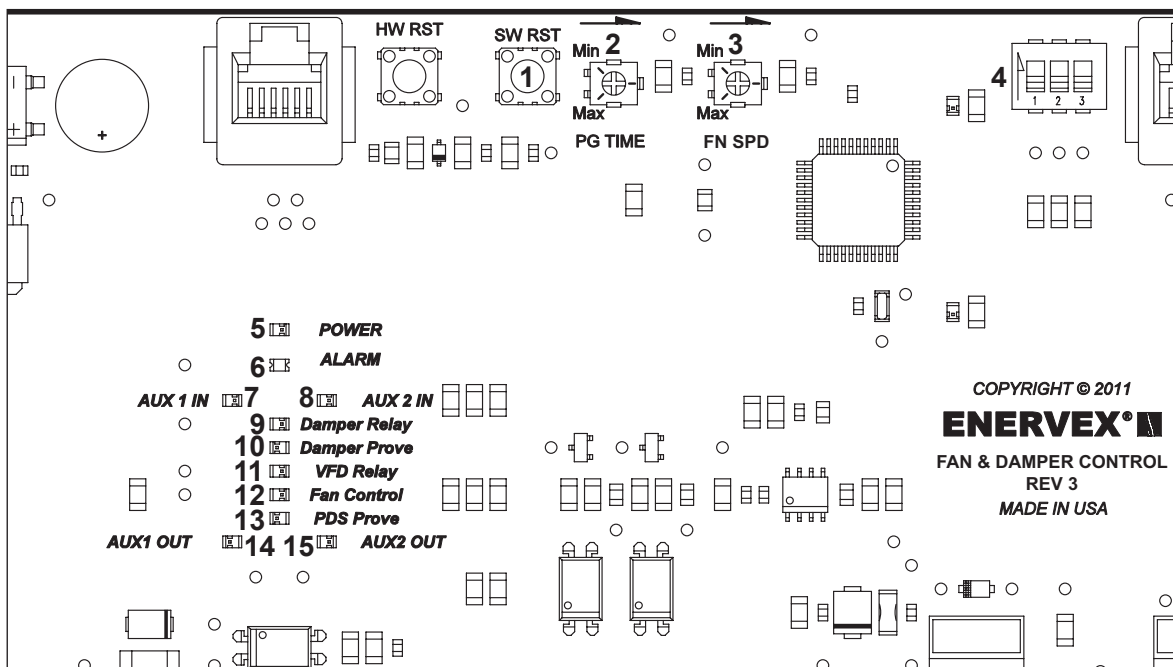

Prior to start up, please review the paragraph below.

**Dipswitch settings**

Prior to starting the system, check to see if the dipswitch settings are as required.

- Default factory setting: All OFF
- If the factory setting must be changed, the dipswitches are located in the upper right hand portion of the control board as shown in Figure 14.

Dipswitch	Name	Off	On
1	Manual Reset	Automatic reset on modes of failure	<ul style="list-style-type: none"> <li>• Manual reset on all modes of failure</li> <li>• Manual Reset button must be pressed for 2 sec. to clear all alarms</li> </ul>
2	Post Purge	No post-purge	3 minutes of post purge.
3	PDS Check	No monitoring to see if the PDS was in NC position prior to start. NO must be closed at all times.	The PDS must be in NC prior to start. No must close after start.

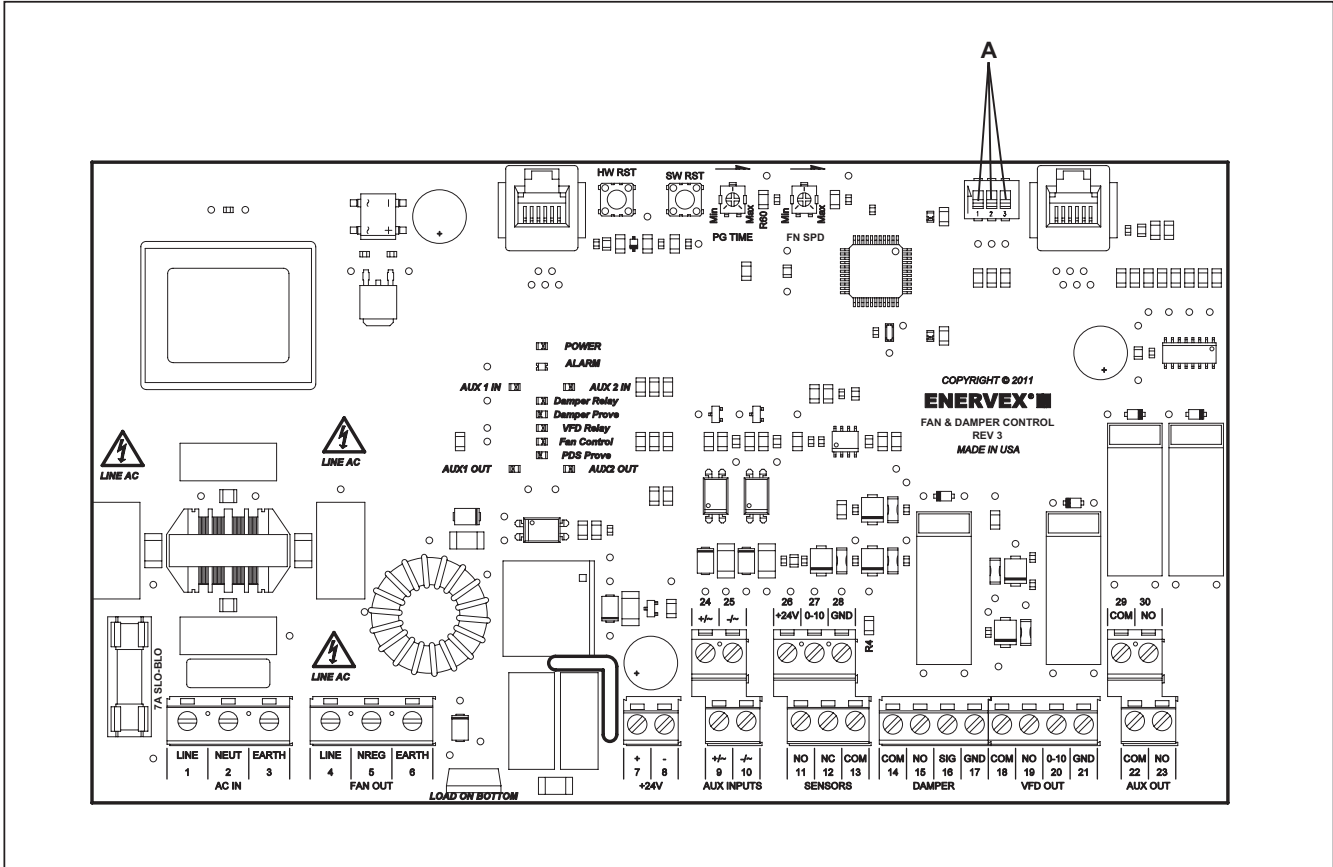

Fig. 14



---

## Sequence of Operation

### Start Sequence

1. A call for heat from the appliance(s) energizes the ADC150 inputs at terminals 9 & 10 (and/or terminals 24 and 25).
2. If a damper is connected, the Damper Relay closes, to open the damper. Once the damper is proven open (Damper Prove LED), the ADC150 will begin to modulate the fan either through the 120V AC output (terminals 4-6) or the VFD output (terminals 18-21).
3. Once the PDS Prove circuit and the XTP sensor senses sufficient draft and has met set point, the ADC150 releases the appliance for operation by closing the dry contact(s) on terminals 22 and 23 (and/or terminals 29 and 30).

### Shutdown Sequence

1. The call for heat from the appliance(s) is removed from the ADC150.
2. The control will stop modulating the fan output to maintain setpoint.
3. The Damper Relay opens to close the damper.
4. The control will enter an idle state and await the next call for heat from the appliance(s).
5. If Post Purge is set to ON (refer to section 5.1), the control will maintain setpoint for an additional 3 minutes prior to beginning Step 2 of the Shutdown Sequence.

\*Refer to chart on the next page for representation of Sequence of Operation

# Sequence of Operation - Flow Chart (Default Dipswitch Setting - All Off)

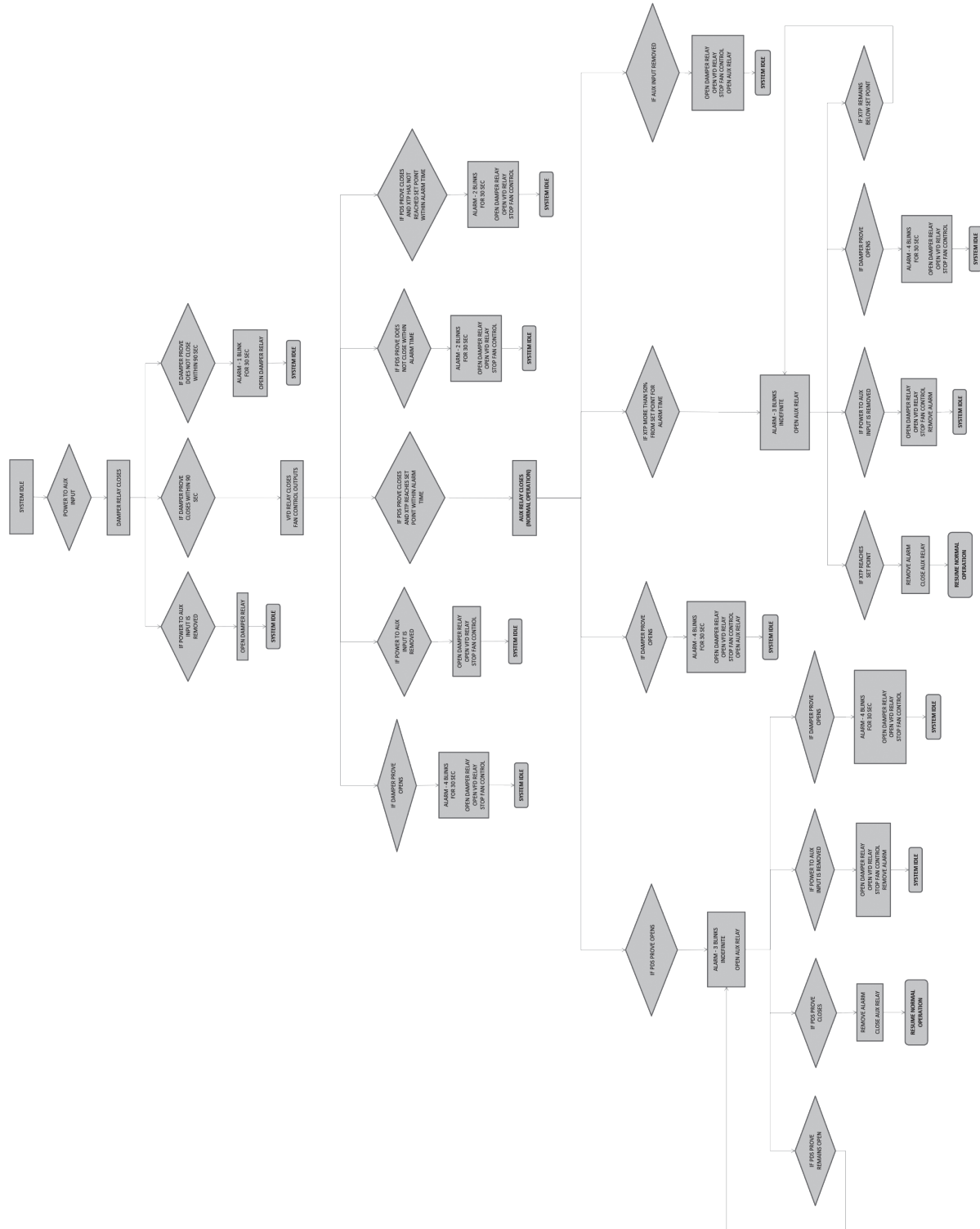

## 5.2 SETTING OPERATION PRESSURE

The pressure setting of the ADC150 must be adjusted to assure proper draft for the appliance.

The ADC150 has an adjustment range between 0.05" W.C. (full counter-clockwise) to 0.55" W.C. (full clockwise), see Figure 15.

To adjust the pressure set-point of the system, follow the procedure outlined below:

1. Rotate the FAN SPD potentiometer counter-clockwise.
2. Insert a manometer into the duct system, preferably at the same location as the duct probe where the constant pressure is to be maintained.
3. Start the building exhaust system and wait until the appliances are firing and the draft has stabilized.
4. Check the pressure near the appliance outlet and confirm proper operation of the appliance. If additional draft is required, rotate the FAN SPD potentiometer clockwise until desired draft is reached.
5. (Optional) If the safety circuit of the appliance(s) is wired to the ADC150, check that it shuts down the appliance in an alarm condition. An alarm condition can be simulated by removing the silicone tubing from the negative ( - ) port of the XTP. Wait the allotted alarm time duration and confirm appliance shutdown when the ADC150 is in alarm. Reattach the silicone tubing to the negative ( - ) port of the XTP when complete.

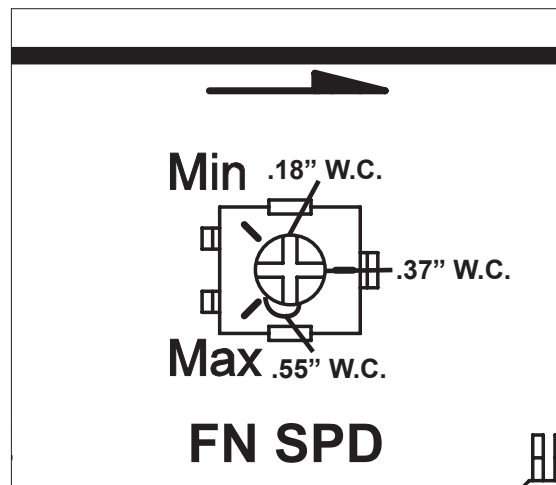
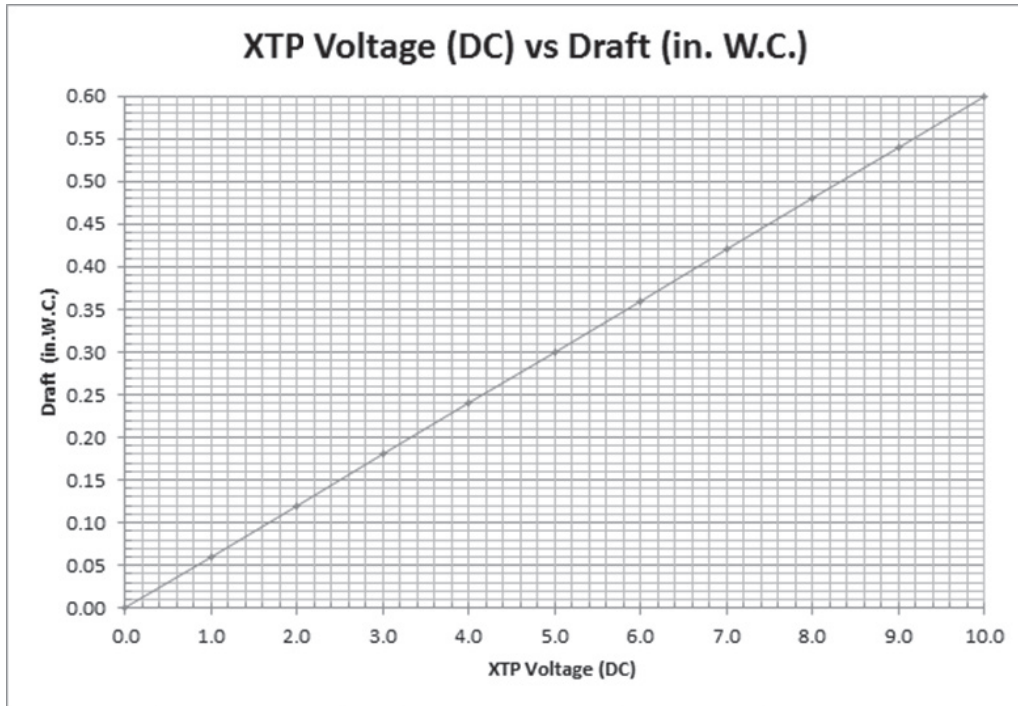

Fig. 15

If a manometer is not available or the stack probe is not located near the control, measure the DC voltage measurement from the XTP terminals (27 +, 28 -) and wait for the measurement to stabilize. Then, use the chart below to correlate the voltage measurement to duct pressure. For example, if the DC voltage measurement is 3 VDC, then the draft at the probe is 0.18" W.C.



For fireplaces, a standard smoke/flame test should be performed before normal operation (specified in the appliance's manual). This test will determine if the draft set point is sufficient or needs adjustment.

### 5.3 Setting Alarm Time

The ADC150 features an adjustable alarm time from 15-180 seconds (factory setting is 15 seconds), see Figure 16.

Alarm time is the duration the control waits prior to going into alarm when it is no longer able to maintain the desired set point.

In some cases, circumstances may require the alarm time be extended past the factory setting of 15 seconds. If needed, the alarm time can be increased by rotating the PG TIME potentiometer clockwise. Refer to Section 5.1 for location of the potentiometer.

To adjust the Alarm Time of the control, follow the procedure outlined below:

1. Adjust pressure set-point as needed following the procedure in section 5.2
2. Rotate the PG TIME potentiometer clockwise. Simulate an alarm condition by removing the silicone tubing from the negative ( - ) port of the XTP. Measure the duration the control takes to go into alarm from the moment the tubing is removed. Repeat and adjust PG TIME potentiometer as needed to obtain desired alarm time.

\* Adhere to local codes when adjusting alarm time

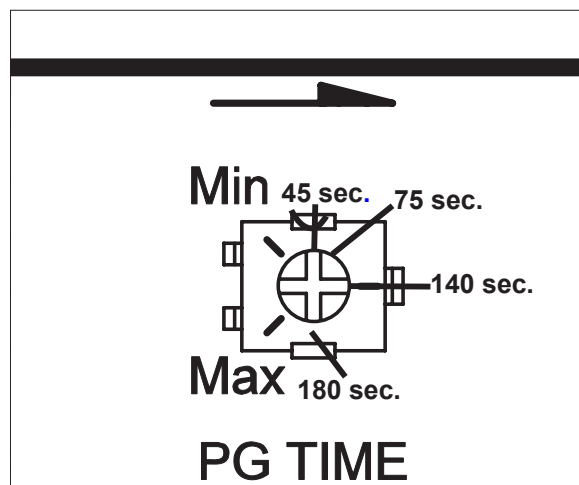

Fig. 16

## 6. Maintenance and Troubleshooting

Alarm Code	Problem
One Flash	Damper Prove circuit did not close on initial startup
Two Flashes	Either PDS or XTP did not indicate
Three Flashes	Either PDS or XTP did not maintain sufficient draft after the system has met setpoint
Four Flashes	Damper prove circuit failed to maintain closure once the system has met setpoint
Five Flashes	PDS Prove is already closed when the startup sequence is initiated with the PDS Check Dipswitch ON.



Some appliances require a certain startup procedure after a shutdown. Follow this procedure prior to pressing the RESET button.