

URBANA

LUXURY FIREPLACES

U55 FIREPLACE

Installation Reference Guide

REFER TO OWNER'S MANUAL FOR SPECIFIC INSTALLATION REQUIREMENTS AND ADDITIONAL PRODUCT INSTRUCTIONS

Minimum Framing Dimensions

Note: When framing the unit, care must be taken to consider the final floor thickness, the bottom of the fireplace must sit flush with the finished floor to ensure proper fit of the surround components

Note: Vent size: 8 x 11" Rigid Co-Axial

Minimum Depth (2" facing mat.)	26.5"	660 mm
Maximum Depth (1/2" facing mat.)	28"	698 mm
Width	63 1/2"	1359 mm
Header Height	60 1/4"	1283 mm
Enclosure Ceiling	108"	2743mm

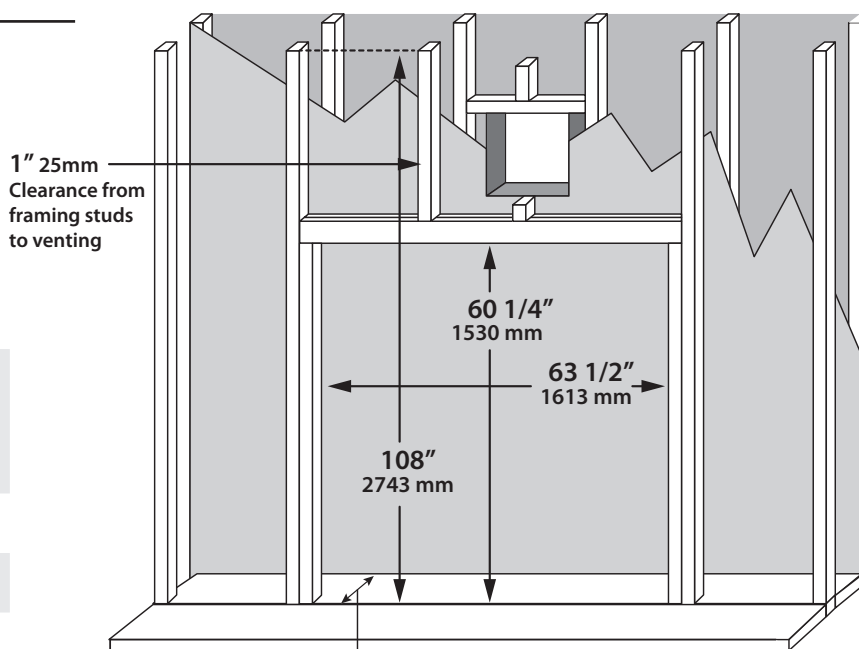

Refer to Table on left

Clearance to Combustibles

A - Finishing edge to side wall	3 1/2"	89 mm
B - Minimum clearance to enclosure ceiling	108"	2743 mm
C - Minimum clearance to mantel height	60"	1524 mm
D - Front of door to edge of floor protection	0"	0 mm
E - Minimum alcove width	62"	1575 mm

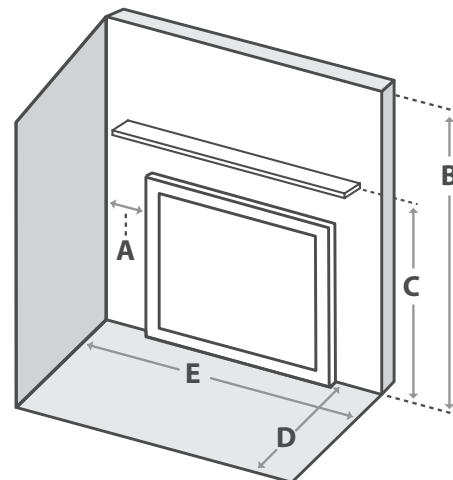

Non-Combustible Board Placement

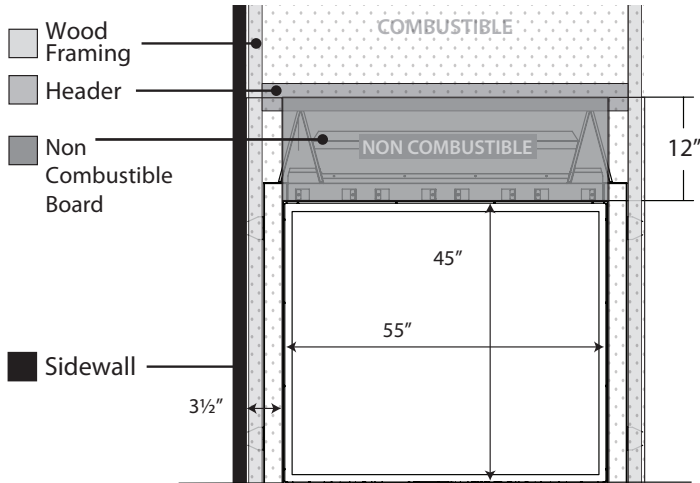

Fireplace Dimensions

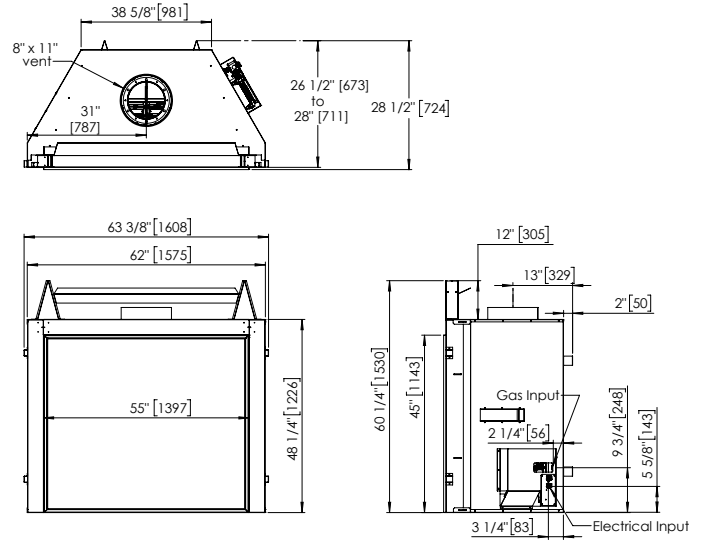

Minimum Venting Requirements

This appliance uses a 11" (280 mm) exhaust / 8" (203mm) air intake vent pipe system. For safe and proper operation of the appliance follow the venting instructions exactly. Deviation from the minimum vertical length can create difficulty in burner start-up and sooting. Allow several minutes for the flame to stabilize after ignition under extreme vent configurations. It is recommended for vent lengths that pass through unheated spaces (garages, attics, crawl spaces) be insulated to minimize condensation.

NOTE: At least 21 (533mm) of clearance is required above vent when passing through an exterior wall when horizontally terminating.

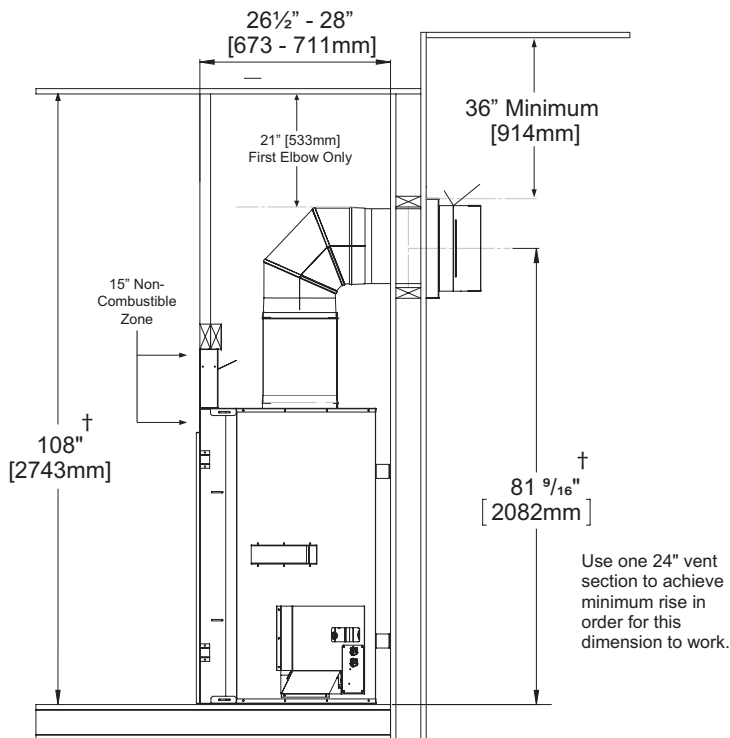

Mantel Projections

Mantel graph dimensions are measured from the bottom of the fireplace, if you wish to reference the mantel height from the tiling edge subtract 45 inches (1143mm) from the mantel height depicted on the graph. If you plan to install a TV above your fireplace refer to the appropriate section of the owner's manual for available options. It is acceptable to install a combustible mantel over top of the non-combustible board. If using the Cool Surface System, refer to the graph on the following page to determine the required mantel height.

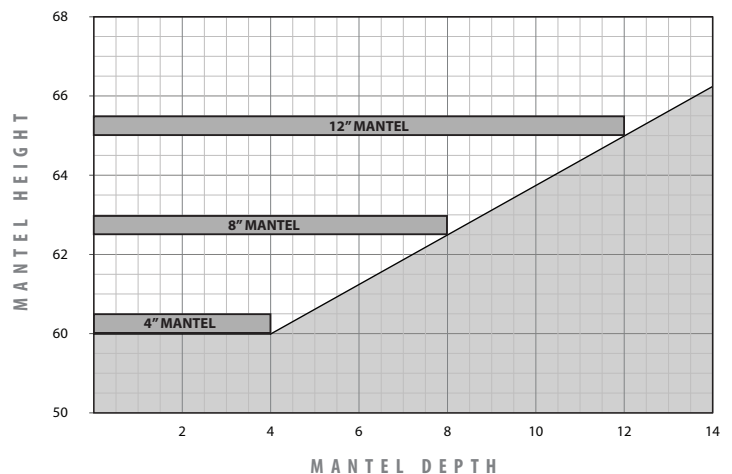

Mantel Projections with Cool Surface System

Activating the Cool Surface System decreases the required height of the mantel. Use the graph on the right to determine the mantel height when using the Cool Surface System. Mantel graph dimensions are measured from the bottom of the fireplace, if you wish to reference the mantel height from the tiling edge subtract 45 inches (1143mm) from the mantel height depicted on the graph. If you plan to install a TV above your fireplace refer to the appropriate section of the owner's manual for available options. It is acceptable to install a combustible mantel over top of the non-combustible board.

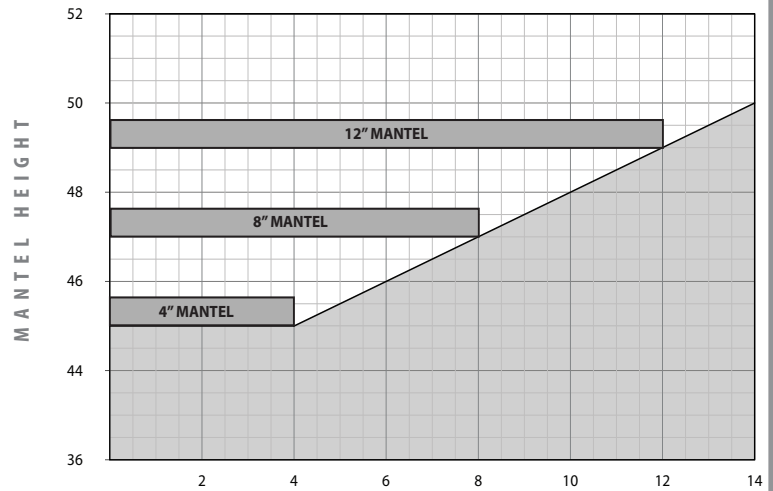

Cool Surface System Framing

Framing Option 1: Front Discharge (flush wall installations)

Construct the framing in a way that provides a minimum 53 inch (1067mm) by 3 inch (76mm) gap at the top of the facing wall. It is essential that these dimensions are respected and not to deviate away from them when using combustible materials inside the chase (see Figure 1).

Note: If you wish to construct the CSS air discharge part way up a tall wall then it is essential to build a false ceiling inside the chase at the desired height to direct the rising heat out of the gap.

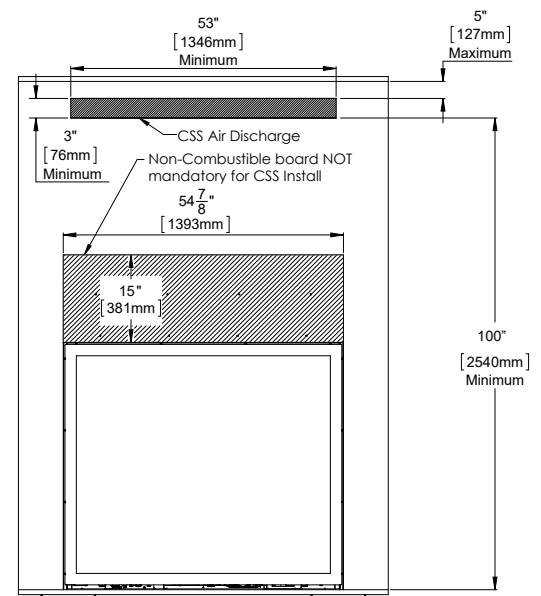

Figure 1: Framing Option 1

Framing Option 2: Open Chase (built-out installations)

This could be considered the most discreet option when considering the CSS. The chase must be constructed in a way that stops short of the ceiling, leaving it totally vented above. Minimum framing dimensions must be followed when constructing this option and not to deviated from them when using combustible materials. Consider Optional 3: Valance to work in conjunction with this option.

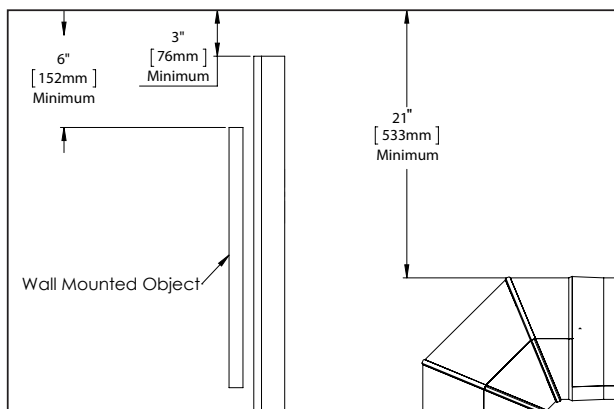

Figure 2: Open Chase

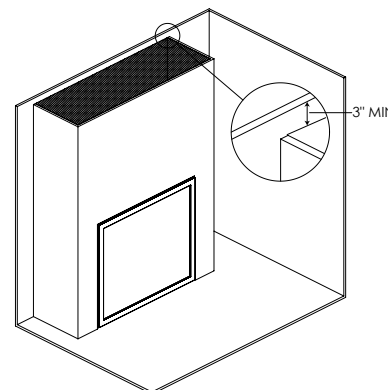

Figure 3: Open Chase Iso View

Cool Surface System Framing

Framing Option 3: Valance

A valance may be desired to accentuate or hide the CSS outlet. Consider framing option 1 or 2 to utilize the valance feature. This is an optional decorative feature that covers up the CSS outlet gap. Minimum opening and valance dimensions must be followed to ensure safe heat dissipation. Combustible material is acceptable when constructing the valance. It is acceptable to wrap the valance around the three sides of a built out chase (Option 2).

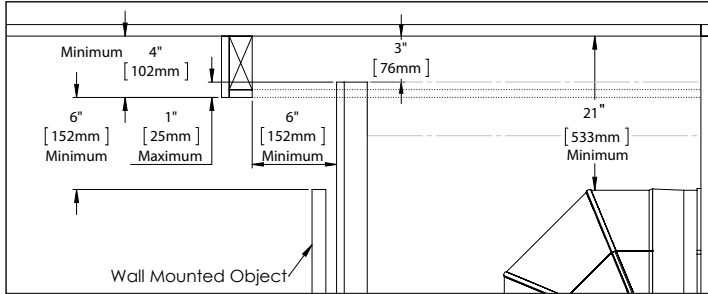

Figure 4: Valance Install

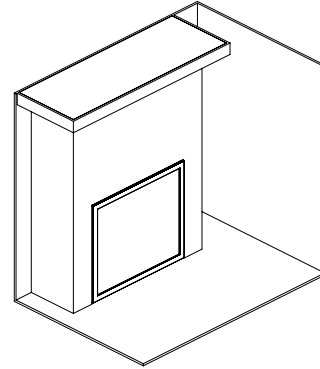

Figure 5: Valance Iso View

Framing Option 4: Side Discharge

Construct the framing in a way that provides two gaps, one on each side of the chase as shown in Figure 7. Each gap should be a minimum of 21 inch (533mm) by 3 3/4 inch (95mm). It is essential that these dimensions are followed and not to deviated from them when using combustible materials inside the chase (see Figure 6).

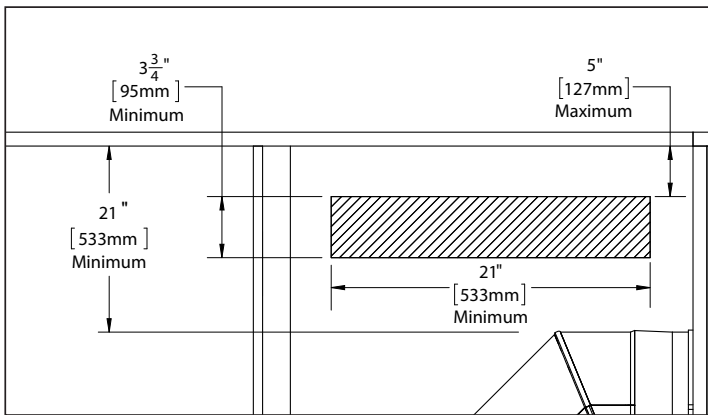

Figure 6: Side Discharge

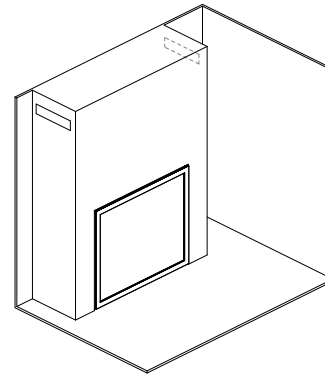

Figure 7: Side Discharge Iso View

Optional: False Ceiling

If your ceiling dimension is greater than the minimum (See Figure 1) You may want the CSS air discharge lower on the wall. This false ceiling is required to properly evacuate heat from the chase. (See Figure 8).

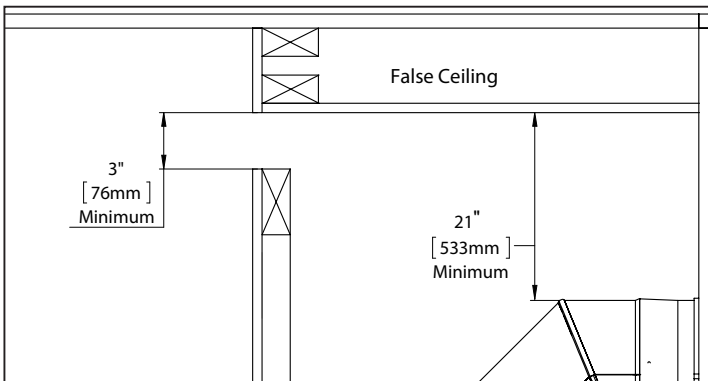

Figure 8: False Ceiling

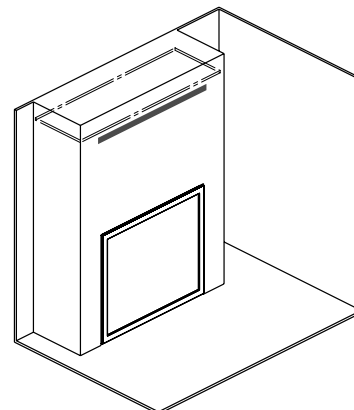

Figure 9: False Ceiling Iso View