

### MODEL SDF200



### WARNING

#### WARNING — THE INSTALLATION MUST BE CARRIED OUT BY A QUALIFIED TECHNICIAN

1. Ducted fans **MUST** be vented to outdoors
2. Dryer Booster Fans can only be installed by a qualified technician
3. These units are **NOT** to be used to exhaust hazardous or explosive gases
4. To avoid damage to motor and impeller, keep construction materials such as dry wall spray, construction dust, construction debris, etc. off power units and ducts leading to units

#### Application Notice

1. Be sure the unit is oriented in the correct direction (i.e. intake on the dryers side, etc.)
2. Before wiring, servicing or cleaning the units, switch power OFF at the service panel and lock it
3. **DO NOT** install if duct work has been damaged or when there are restrictive turns reducing airflow
4. When cutting or drilling into wall or ceiling, **DO NOT** damage electrical wiring and other hidden utilities
5. Always vent units to the outdoors— **NOT** into unventilated spaces such as garages, attics, crawl spaces, etc.
6. Use this unit only in the manner intended by the manufacturer. Contact the manufacturer in case of questions
7. Ducted fans **MUST** always be vented to the outdoors. **DO NOT** suspend from lathing channels or drywall. The unit **MUST** be grounded
8. **DO NOT** install this fan where the temperature may exceed +60°C. Unit **MUST** be installed at least 8 feet above the floor on/in the ceiling or wall
9. All fans should have back draft damper at outlet. Fans with pressure sensing device **MUST** have wall-box equipped with back draft damper
10. If service panel is unlocked, others could turn the power on unexpectedly and cause fatal electric shock to the installer or service person
11. It is recommended that a Lint Trap be installed. Then the location of the booster fan can be 15' to 20' (10 linear feet) from the dryer
12. Installation work and electrical wiring must be done by a qualified person(s) in accordance with all applicable codes and standards, including fire-rated construction codes and standards. The booster fan blade **MUST** be checked at least twice annually for lint accumulation

### CAUTION

#### PLEASE READ INSTRUCTION BEFORE COMMENCING INSTALLATION AND RETAIN FOR FUTURE REFERENCES.

Electrical products can cause death or injury, or damage to property.

If in any doubt about the installation or use of this product, consult a competent technician.

### CLEANING & MAINTENANCE

1. Before cleaning the unit, switch power OFF at service panel and lock it. If the service panel is unlocked, others could turn the power on unexpectedly and cause fatal electric shock to the cleaner
2. Make sure there is no power to the motor
3. Clean blower wheel of lint accumulation with a cloth or small smooth brush as required (at least twice annually) by removing two wing nuts from the motor plate then motor will swing open
4. Tighten the wing nuts after cleaning
5. Turn the power ON and check if the fan is working properly
6. It is recommended that a Lint Trap be installed

### INSTALLATION GUIDE

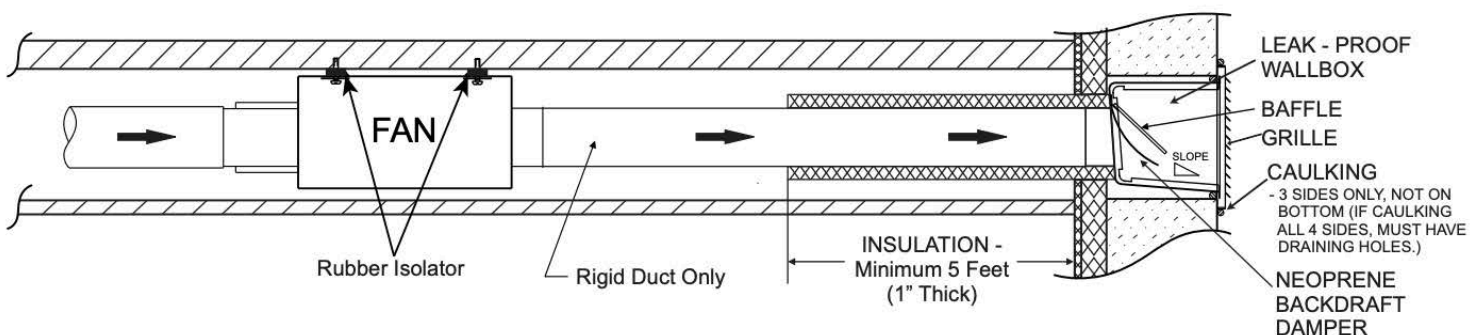

## MODEL SDF200

### INSTALLATION GUIDE

#### Important Reminder

USE AS FEW ELBOWS AS POSSIBLE. We strongly recommend the ductwork be as straight as possible with minimal restriction to airflow. DO NOT install and operate if you encounter ductwork is unusual configuration that would restrict airflow such as the diagram on the right side:

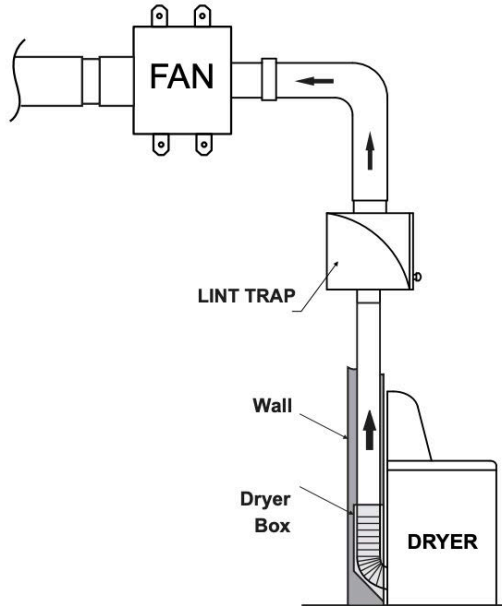

#### Mounting the Fan (SDF200)

A mounting bracket and hardware pack is included and should be utilized to rigidly mount the fan to a wall stud, rafter, or joist. Electrical box **MUST** be mounted in the vertical plane for correct pressure sensing. If mounted horizontally, a 1/8" weep hole may need to be drilled in the bottom of the fan in order to prevent water from accumulating at the lowest point.

#### Horizontal

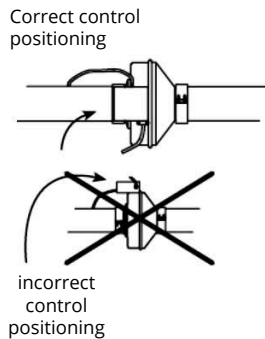

#### Angled

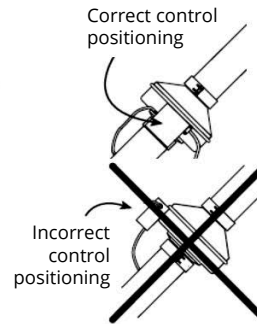

#### Vertical

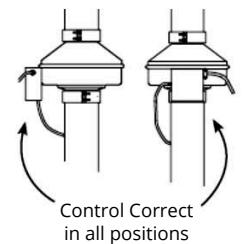

1. Hold the mounting bracket against the surface it is to be mounted
2. Mark the location of the two most useful key slots and remove the bracket. Using the provided 3/4" long wood screws, attach screws into the structure leaving 1/8" space between the screw head and mounting surface
3. Using the provided self-tapping screws, attach the bracket to the fan (see fig.1)
4. Holding the new assembled fan and bracket, align the key slots with the mounting screws and lock them into place

Fig.1

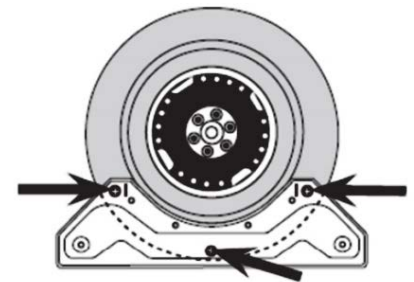

#### Pressure Switch (SDS-10) Connection

DO NOT connect the tubing in such a manner as to allow condensation from the duct to collect in the tubing. Drill a 3/8" diameter hole in the duct wall to 6"-8" from the inlet of the fan. Carefully insert the grommet into the hole.

Drilling into a metal may produce sharp burrs.

Needle nose pliers can be used to remove or flatten sharp edges.

1. Attach one end of the clear pressure tubing to the pressure sensor located on the electrical box
2. Mark the opposite end of the pressure tubing 1/2" from the edge and insert into the grommet until the marking is reached

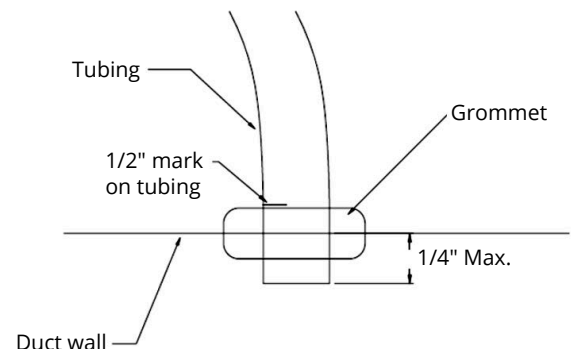

## MODEL SDF200

### SDS-10 (PRESSURE SENSING SWITCH) OPERATION

#### Electrical Specifications

##### Electrical Ratings

##### Silver Contracts:

- SPDT, SPST Electrical Load: 1/10 HP at 120-277V AC; 28VA Pilot Duty at 24V AC; 125VA Pilot Duty at 120V AC
- SPST Electrical Load: 3 Amps Resistive at 24 & 120 to 277V AC

##### Terminal Connections

- 1/4" x .032 Quick Connect Terminals
- Switching Action: Change Contact Position on Pressure Rise at Set Point
- Contact Arrangement: SPNO
- Position of Contacts Before Pressure is Applied: 

#### Other Specifications

##### Options Included

- Electronic Cycle Timing Module, 10min—ON—15sec—OFF
- Switch enclosure with removable cover will accept (3) 1/2" conduit connections
- 3 conductor cable with ground, 10" long external length
- Probe accessory kit, with 2" long insert probe and (4) #8 x 1/2 square drive (Type TEK) screws

##### Agency Approvals

- UL / cUL / CSA & CE
- CE ([www.unicontrolinc.com](http://www.unicontrolinc.com) for EU Declaration of Conformity)
- Timer Module approved as an Accessory by UL and cUL

#### Electronic Cycle Timing Module

- Electrical Rating — P.C. Board
- 1VA at 120V AC, 50/60Hz
- Electrical Rating — Contacts
- Terminal 3, 8A at 250V AC, 50/60Hz
- Screw Connector, clamp type terminal block suitable for 12-26AWG
- Timing Range: 10min (600 sec) ± 10%

#### More about the Operation

- Recycling delay timer with 10min—ON—15sec—OFF cycle
- Shown in "On Shelf" condition: No power and no differential pressure applied
- As differential pressure exceeds set point: The snap switch NO contact closes, signaling the microprocessor that the air switch has changed state. The microprocessor will energize the relay and start the timing sequence

### WIRING & MOTOR REPLACEMENT PROCEDURE

#### Connect Electrical Wiring

Run 120V AC house wiring to the location of the fan. Use only UL-approved connectors (not included) to attach the house wiring to the wiring plate. Refer to the wiring diagram on the right, and connect the wires as shown.

#### Important Reminder:

Wiring the fan should be completed by a skilled licensed professional in accordance to all codes applicable to the municipality and/or national codes. Ensure that the wiring nuts on the access door panels are tight and secure. There are moving parts. Disconnect power supply preferably at the service panel. Connect to the control of your choice such as: Amp Sensor (AS) or Pressure Switch (SDS-10). Contact the manufacturer for further details if necessary.

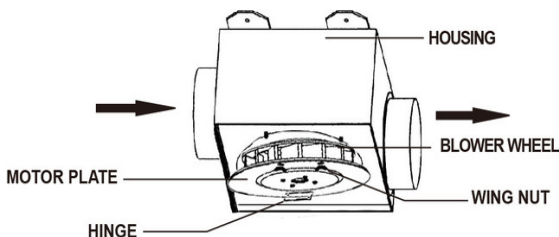
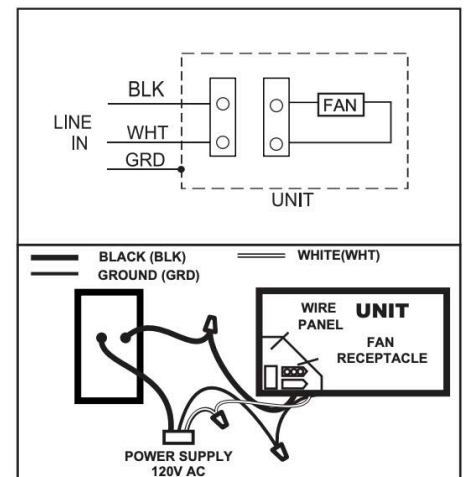

#### Motor Replacement Procedure

1. Disconnect power supply at the panel
2. Remove the electrical box cover and disconnect the wiring to the motor and the ground wire
3. Remove the motor from the motor plate
4. Remove the mounting bracket from the old motor
5. Install the mounting bracket to the new motor
6. Install motor to the motor plate
7. Tighten the wing nuts with washer and secure the motor plate
8. Connect the electrical wires including the ground
9. Replace the electrical cover and turn ON power supply at the panel

ORTECH reserves the right to modify at any time, without notice, any or all of our product's features, designs, components and specifications to meet market changes.